



Installing and Maintaining the E300 System



Force10

Notes, Cautions, and Warnings

-  **NOTE:** A NOTE indicates important information that helps you make better use of your computer.
-  **CAUTION:** A CAUTION indicates potential damage to hardware or loss of data if instructions are not followed.
-  **WARNING:** A WARNING indicates a potential for property damage, personal injury, or death.

Information in this publication is subject to change without notice.

© 2010 Dell Force10. All rights reserved.

Reproduction of these materials in any manner whatsoever without the written permission of Dell Inc. is strictly forbidden.

Trademarks used in this text: Dell™, the DELL logo, Dell Precision™, OptiPlex™, Latitude™, PowerEdge™, PowerVault™, PowerConnect™, OpenManage™, EqualLogic™, KACE™, FlexAddress™ and Vostro™ are trademarks of Dell Inc. Intel®, Pentium®, Xeon®, Core™ and Celeron® are registered trademarks of Intel Corporation in the U.S. and other countries. AMD® is a registered trademark and AMD Opteron™, AMD Phenom™, and AMD Sempron™ are trademarks of Advanced Micro Devices, Inc. Microsoft®, Windows®, Windows Server®, MS-DOS® and Windows Vista® are either trademarks or registered trademarks of Microsoft Corporation in the United States and/or other countries. Red Hat Enterprise Linux® and Enterprise Linux® are registered trademarks of Red Hat, Inc. in the United States and/or other countries. Novell® is a registered trademark and SUSE™ is a trademark of Novell Inc. in the United States and other countries. Oracle® is a registered trademark of Oracle Corporation and/or its affiliates. Citrix®, Xen®, XenServer® and XenMotion® are either registered trademarks or trademarks of Citrix Systems, Inc. in the United States and/or other countries. VMware®, Virtual SMP®, vMotion®, vCenter®, and vSphere® are registered trademarks or trademarks of VMWare, Inc. in the United States or other countries.

Other trademarks and trade names may be used in this publication to refer to either the entities claiming the marks and names or their products. Dell Inc. disclaims any proprietary interest in trademarks and trade names other than its own.

Contents

- 1 About this Guide
 - Information Symbols and Warnings 7
 - Related Publications 8

- 2 The E300 System
 - E300 System Installation Process 11

- 3 Site Preparation
 - Site Selection Criteria 13
 - Rack Mounting 14
 - Cabinet Placement 14
 - AC and DC Power 14
 - 2500W AC Power 14
 - DC Power 15
 - Fans and Airflow 16
 - Storing Components 16

- 4 Installing the Chassis
 - Safety Considerations 17
 - Installing the Chassis into an Equipment Rack 17
 - Installing the Chassis into an Equipment Cabinet 18

- 5 Installing Power Modules
 - Installing AC Power Modules 19
 - AC Power Requirements 20
 - AC Power Cord Requirements 20
 - Installing an AC Power Supply 22
 - Installing DC Power Entry Modules 22
 - DC Requirements 23
 - Redundancy 23
 - Cable and Connector Requirements 23
 - Removing a DC PEM 24
 - Installing a DC PEM 25
 - Power Supply and Fan Operability Test 27

- 6 Installing E300 Fan Tray

- 7 Installing RPMs, Line Cards, and SFMs
 - RPMs 31

Blank Panels	31
Unpacking Cards	31
Installing the RPMs and Line Cards	32
Installing a Second RPM	32
RPM Label and LEDs	33
Line Card LEDs	34
Expandable Cable Management Bracket	34
Installing Switch Fabric Modules (SFMs)	35
8 RPM Ports and Cables	
Connecting the Console and Auxiliary Ports	39
Cable and Adapter Pin Assignments	39
Accessing the Console with a DB-9 Adapter	40
Accessing the Console with a DB-25 Adapter	41
Accessing the Auxiliary Port by Modem	41
Accessing the 10/100 Ethernet Management Port	42
9 Powering Up	
Preparation	43
Supplying Power	43
Booting to the CLI Prompt	44
Booting from the BOOT_USER Prompt	44
10 Removing and Replacing Components	
Removing and Replacing the Fan Tray	45
Removing and Replacing Power Module	46
Removing and Replacing RPMs, Line Cards, or SFMs	47
Removing and Replacing the Air Filter	48
A System Boot	
Booting from the BOOT_USER Prompt	51
B The Compact Flash Card	
Inserting the Compact Flash Card	55
Removing the Compact Flash Card	55
Formatting a Compact Flash Card	56
C Alarms	
AC Power Supplies and Alarms	58

D	System Specifications	
	Chassis Physical Design	59
	Environmental Parameters	60
	Power Supplies System Power Requirements	60
	Module Power Requirements	61
	Agency Compliance	61
	Safety Standards and Compliance Agency Certifications	62
	Electromagnetic Compatibility (EMC)	63
	Product Recycling and Disposal	63
E	Technical Support	
	The iSupport Website	65
	Accessing iSupport Services	65
	Contacting the Technical Assistance Center	66
	Requesting a Hardware Replacement	66
	Locating E300 Serial Numbers	67
	 Index	

About this Guide

This guide provides site preparation recommendations, step-by-step procedures for installing the Dell Force10 E300 chassis, as well as instructions to install the fan tray, power supplies, route processor modules (RPMs), switch fabric modules (SFMs), and line cards.

This guide also includes instructions to remove and install field-replaceable parts. The E300 system is packaged with components necessary for optimal performance, including panel blanks for RPMs, SFMs, and line card slots, and, as required, power module blanks. Blanks are required in empty slots to ensure adequate system cooling, provide for personal safety, and for EMI containment during operation.



After you have completed the hardware installation process and power up the system, refer to the *FTOS™ Configuration Guide* for preliminary software configuration information. *FTOS™ Command Line Interface Reference* provides details to configure Layer 2, Layer 3, and other network parameters.

Information Symbols and Warnings

The following graphic symbols are used in this document to bring attention to hazards that exist when handling the E300 and its components. Please read these alerts and heed their warnings and cautions.

[Table 1-1](#) describes symbols contained in this guide.

Table 1-1. Information Symbols

Symbol	Warning	Description
	Note	This symbol informs you of important operational information.
	Caution	This symbol informs you that improper handling and installation could result in equipment damage or loss of data.
	Warning	This symbol signals information about hardware handling that could result in injury.

 **WARNING:** The installation of this equipment shall be performed by trained and qualified personnel only. Read this guide before installing and powering up this equipment. This equipment contains two power cords. Disconnect both power cords before servicing.

 **WARNING:** This equipment contains optical transceivers, which comply with the limits of Class 1 laser radiation.



 **WARNING:** Visible and invisible laser radiation may be emitted from the aperture of the optical transceiver ports when no cable is connected. Avoid exposure to laser radiation and do not stare into open apertures.

- △ **CAUTION:** Wear grounding wrist straps when handling this equipment to avoid ESD damage.
- △ **CAUTION:** Earthing (AKA grounding) connection essential before connecting supply. Always make the ground connection first and disconnect it last.
- △ **CAUTION:** Disposal of this equipment should be handled according to all national laws and regulations. See [Product Recycling and Disposal on page 63](#).

Related Publications

For more information about the E300 system, refer to the following documents:

- *FTOS Configuration Guide*
- *FTOS Command Line Interface Reference*
- *E-Series® and FTOS Release Notes*

The E300 System

The Dell Force 10 E300 System is a high performance, low cost switch/router. The eight-slot system contains two slots for route processor modules (RPMs) and six slots for line cards. The two Switch Fabric Modules (SFMs) are required for line rate packet processing.

Figure 2-1. E300 Chassis Front View

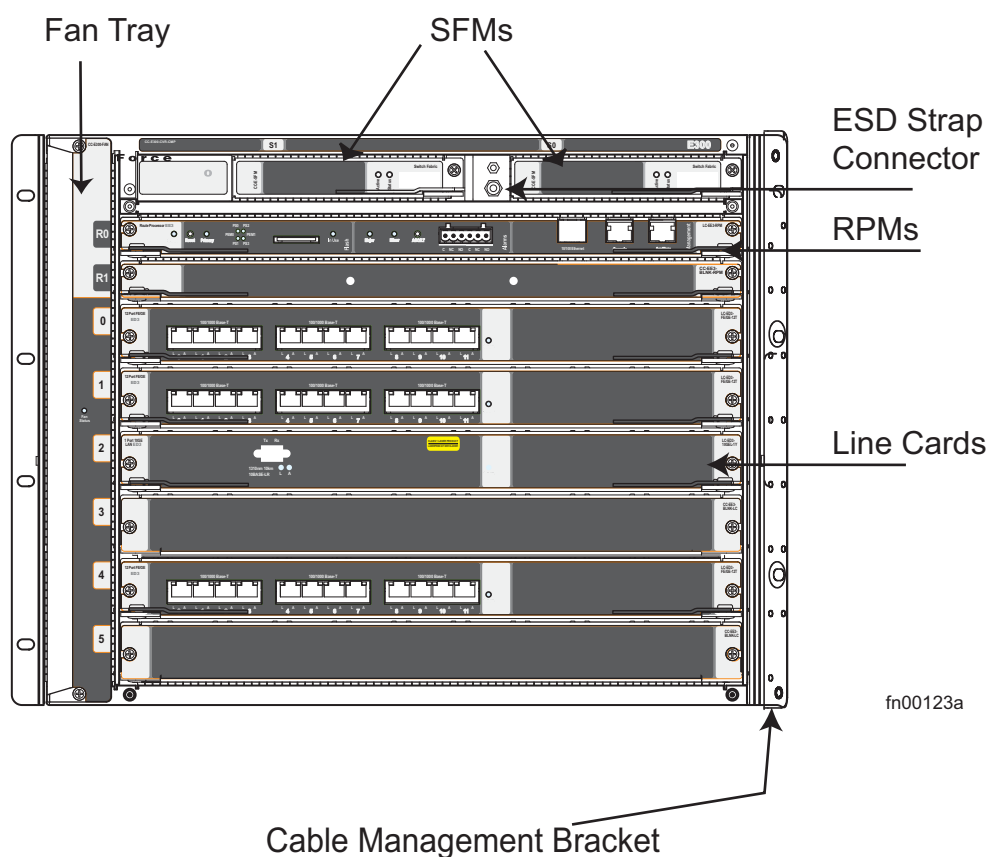

Figure 2-2. E300 Chassis Rear View with AC Power Supplies

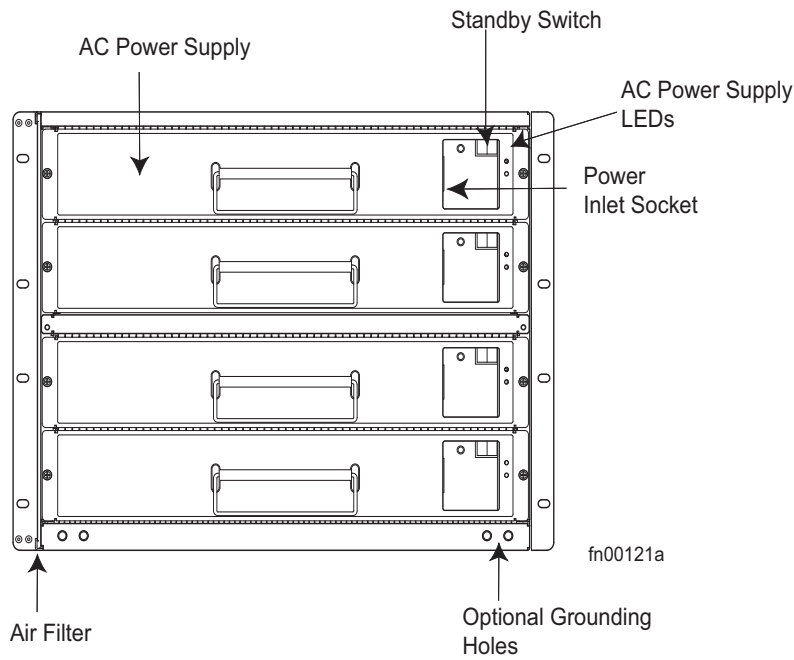

Figure 2-3. E300 Chassis Rear View with DC PEMs

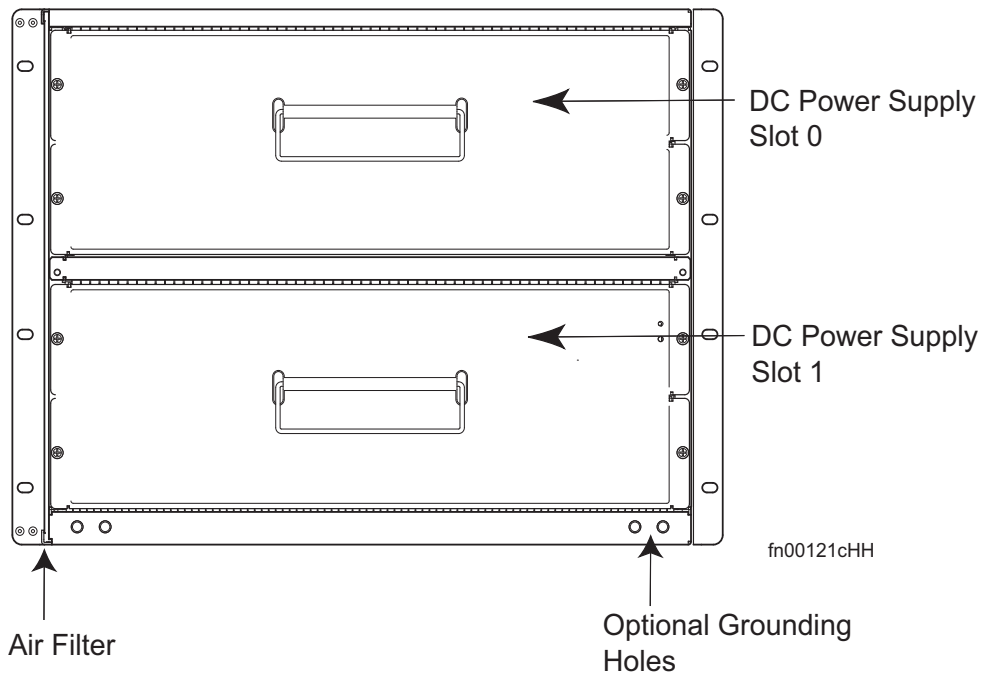

Table 2-1 lists the minimum and maximum components required to run the E300 System.

Table 2-1. E300 Component Requirements

Component	Minimum	Maximum	Field-Replaceable?
Backplane (factory installed)	1	1	No
Air filter	1	1	Yes
Fan tray	1	1	Yes
RPMs	1	2	Yes
Line cards	1	6	Yes
SFMs	1*	2	Yes
Power Supplies:			
AC Power Supply (100 - 120 VAC)	3	4	Yes
AC Power Supply (200 - 240 VAC)	2	4	Yes
DC Power Entry Module (PEM)	1	2	Yes
Cable management bracket	0	2	Yes

*With one SFM, the E300 does not transmit traffic at line rate.

E300 System Installation Process

To install the E300 System, Dell Force10 recommends that you install the chassis and modules in the following order:

Step	Task	Relevant Section in the Manual
1	Prepare the Site	Site Selection Criteria on page 13
2	Unpack the chassis and components	Storing Components on page 16
3	Mount the chassis	Installing the Chassis into an Equipment Rack on page 17 or Installing the Chassis into an Equipment Cabinet on page 18
4	Install components: <ul style="list-style-type: none"> • Fan Tray • AC Power Supply or DC PEMs 	Installing E300 Fan Tray on page 29 Installing Power Modules on page 19
5	Verify power supplies and air flow	Power Supply and Fan Operability Test on page 27
6	Install RPMs, line cards, and SFMs	Installing RPMs, Line Cards, and SFMs on page 31
7	Connect network cables	RPM Ports and Cables on page 39
8	Supply power to the Chassis	Powering Up on page 43

After you supply power to the chassis, the software boots to the run-time CLI prompt. To interrupt the boot process, enter the break key sequence (CNTRL-SHIFT-6) and enter the BOOT_USER mode. Refer to [Appendix A, System Boot, on page 51](#) for more information on the BOOT_USER mode.

Site Preparation

This chapter describes the requirements and procedures for installing your E300. The topics covered are:

- “Site Selection Criteria” on page 13
- “Rack Mounting” on page 14
- “Cabinet Placement” on page 14
- “AC and DC Power” on page 14
- “Fans and Airflow” on page 16
- “Storing Components” on page 16

For complete E300 System Specification, refer to [Appendix D, System Specifications, on page 59](#).

Site Selection Criteria

Before beginning the installation process, make sure that the area where you intend to install your E300 meets the following safety requirements:

- In a restricted access area.
- In a dry, clean, well-ventilated and temperature-controlled room, away from heat sources such as hot air vents or direct sunlight.
- Away from sources of severe electromagnetic noise.
- Near an adequate power source. Connect the E300 System to the appropriate branch circuit protection as defined by local electrical codes.
- Ensure adequate space in the front, rear, and sides of the unit for proper ventilation, access to cables, and maintenance access:
 - Wall Clearance—Allow *at least* six inches (16 cm) of clearance around the side intake and exhaust vents and the wall.
 - Side-by-Side—Allow *at least* 12 inches (30.5 cm) between two E300s or an E300 and another side-by-side airflow chassis.
 - Rack—Allow *at least* 18 inches in the front and 20 inches in the rear of the rack.
 - Cabinet—Allow *at least* 3 inches clearance between the cable management panel on the chassis and the closed doors.

 **WARNING:** Lift the E300 chassis *only* from the bottom. Lifting by the chassis shelves or power module openings will damage the chassis. Dell Force10 recommends using an equipment lift or pallet jack to lift and install your E300 chassis into your rack or cabinet. Complete the chassis installation into the rack or cabinet before inserting any components (fan tray, power modules, line cards etc.) into the chassis.

Rack Mounting

When you prepare your equipment rack:

- Make sure the rack is bolted to the floor and/or braced to a wall or ceiling.
- Make sure that the rack is grounded to earth ground. The equipment rack must be grounded to the same ground point used by the power service in your area. The ground path must be permanent.
- For an AC Power supply, the power cord is the primary ground.

When you install the chassis:

- Install the E300 chassis in the rack before you install internal components and make network and power connections.
- Use a level to ensure the chassis is installed level.

Cabinet Placement

The cabinet must meet the following criteria:

- Minimum cabinet size is 30 inches deep and 24 inches wide.
- Minimum air flow is 665 cubic feet per minute (CFM).
- Minimum of six inches between the side intake and exhaust vents and a wall. Minimum of three inches between the closed doors and the chassis (the front of the cable management panel), and a minimum of six inches between the chassis rear and the rear of the cabinet with the cabinet door closed.

AC and DC Power

The E300 supports a 2500W AC Power Supply and DC Power Entry Modules (PEM). The E300 must contain only one type of power module; either AC or DC PEM.

WARNING:

- Make your ground connections first. If you do not ground your equipment correctly, excessive electromagnetic emission may result.
- Disconnect all power to the equipment rack or cabinet before chassis installation.
- Never operate the E300 system with both DC and AC power modules installed.
- Never operate the E300 system with an empty fan tray, power module, RPM, SFM, or line card slots. All slots must contain modules or filler panels.
- You must use power cables that meet your local electrical code requirements.

2500W AC Power

The E300 Power Supply is capable of operating at either 100 VAC or 220 VAC. If the E300 is connected to a 100 VAC power supply, three power supply modules are required. A fourth power supply modules will provide redundancy (3 +1).

If the E300 is connected to a 220 VAC power supply, two power supply modules are required; four power supply modules are required for full facility redundancy (2 + 2).

For installation instructions, see [Installing AC Power Modules on page 19](#).

2500W AC Power Requirements

Parameters	Specifications
Nominal Input Voltage	100 - 120 VAC Requires a minimum of 3 Power Supplies Installed 200 - 240 VAC Requires a minimum of 2 Power Supplies Installed
Maximum AC Power Supply Input	10 A @ 100 VAC per module 7 A @ 200 VAC per module
Maximum System Power Input	4.80 KVA @ 100 VAC 4.60 KVA @ 220 VAC

DC Power

Each E300 system requires *at least one* load-sharing DC PEM to operate. Two DC PEMs are required for full facility redundancy.

For installation instructions, see [Installing DC Power Entry Modules on page 22](#).

DC PEM Power Requirements

CAUTION:

- This equipment must be connected directly to the DC supply system earthing electrode conductor or to a bonding jumper from an earthing terminal bar or bus to which the D.C. supply system earthing electrode is connected.
- The DC supply source is to be located within the same premises as this equipment.
- There shall be no switching or disconnecting devices in the earthed circuit conductor between the DC source and the point of connection of the earthing electrode conductor.

ATTENTION:

- Ce matériel doit être reccordé directement au conducteur de la prise de terre du circuit d'alimentation c.c. ou à une tresse de mise à la masse reliée à une barre omnibus de terre laquelle est raccordée à l'électrode de terre du circuit d'alimentation c.c.
- La source d'alimentation du circuit c.c. doit être située dans la même pièce que le matériel.
- Il ne doit y avoir aucun dispositif de commutation ou de sectionnement entre le point de raccordement au conducteur de la source d'alimentation c.c. st le point de raccordement à la prise de terre.

Parameter	Specifications
Maximum DC PEM Input Current	60A
Maximum Power Dissipation	2400W

Fans and Airflow

Your E300 chassis contains one field-replaceable fan tray. Air flows through the E300 system toward the fans and is exhausted on the fan side of the chassis. Air circulates from the right side to the left. Minimum air flow is 665 cubic feet per minute (CFM).

For fan access, maintenance and proper ventilation, position a chassis in an equipment rack (or cabinet) with least six inches (16 cm) of clearance around the side intake and exhaust vents and a wall. For free air flow between two E300s or an E300 and another side-by-side airflow chassis, position the chassis at least 12 inches (30.5 cm) apart. For instructions on replacing the fan tray, see [“Removing and Replacing the Fan Tray” on page 45](#).

Storing Components

CAUTION: Do not transport a E300 chassis with the components (line cards, power modules, RPMs, and SFMs) fully installed in the chassis. Place the components in their original protective shipping packaging and insert them back into their original shipping position. Shipping components installed, without their protective packaging, may damage the components and the chassis backplane.

If you do not install your E300 System and components immediately, Dell Force10 recommends you properly store components and all extra field-replaceable parts (spares) until you are ready to install them.

Follow these *indoor* storage guidelines:

- Storage temperature should remain constant ranging from 41° to 104°F (5°C to 40°C)
- Non condensing relative humidity should be maintained with 5 to 95%.
- Store on a dry floor, away from direct sunlight, heat, and air conditioning ducts.
- Store in a dust-free environment.

Installing the Chassis

Safety Considerations

⚠ WARNING: The E300 System is packaged in two separate containers. The chassis container measures 25.5" x 31" x 28" and weighs approximately 135 pounds. The board container measures 24" x 34.5" x 26.5" and weighs approximately 90 pounds. Use an equipment lift or pallet jack to install or lift the chassis. Lifting the chassis by its shelves or fan tray opening will cause chassis damage.

🔧 NOTE: If you are installing the chassis without using a equipment lift or pallet jack, remove all AC power supplies, the fan tray, line cards, RPMs and SFMs from the chassis prior to lifting it.

Installing the Chassis into an Equipment Rack

Ensure there is a minimum of six inches of clearance between the side intake and exhaust vents and any walls. If you are installing two E300s next to each other or an E300 next to another side-by-side airflow chassis, position the chassis at least 12 inches apart.

Prior to installing the E300 in an equipment rack, you must install the equipment rack bar. This bar enables you to easily position the chassis into the rack and stabilizes the chassis.

Figure 4-1. Installing the Equipment Rack Bar

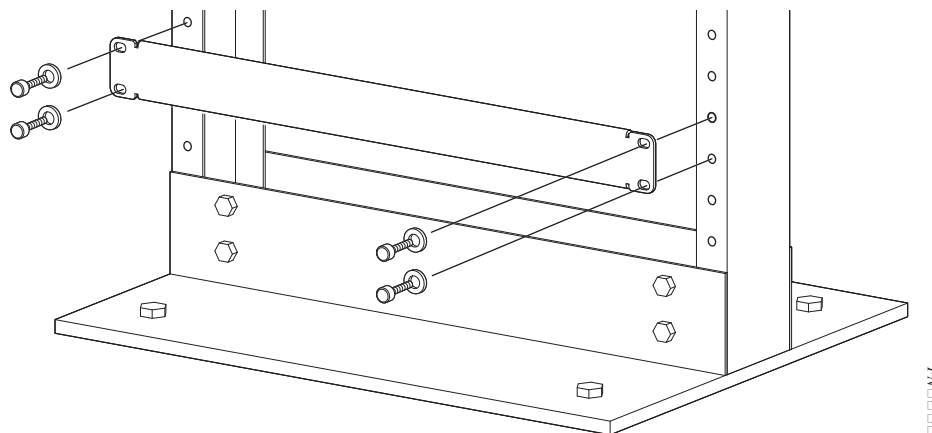

To install the chassis into a 19-inch equipment rack, using the front mounting brackets, follow these steps:

Step	Task
1	At the desired location in the rack, orient the equipment rack bar with the arrows pointing up. The smooth side of the bar should face outward.
2	Using the mounting screws provided with your rack, attach the bar to the rack (see Figure 4-1).
3	Using a hand cart, pallet jack, or forklift, align the rack-mount holes with the equipment rack holes, situating the chassis on top of the equipment rack bar.

Step	Task
4	Using the screws provided with your equipment rack, insert screws into both the chassis rack mounting bracket and the equipment rack and tighten (see Figure 4-2).

Figure 4-2. Rack Mounting the Chassis

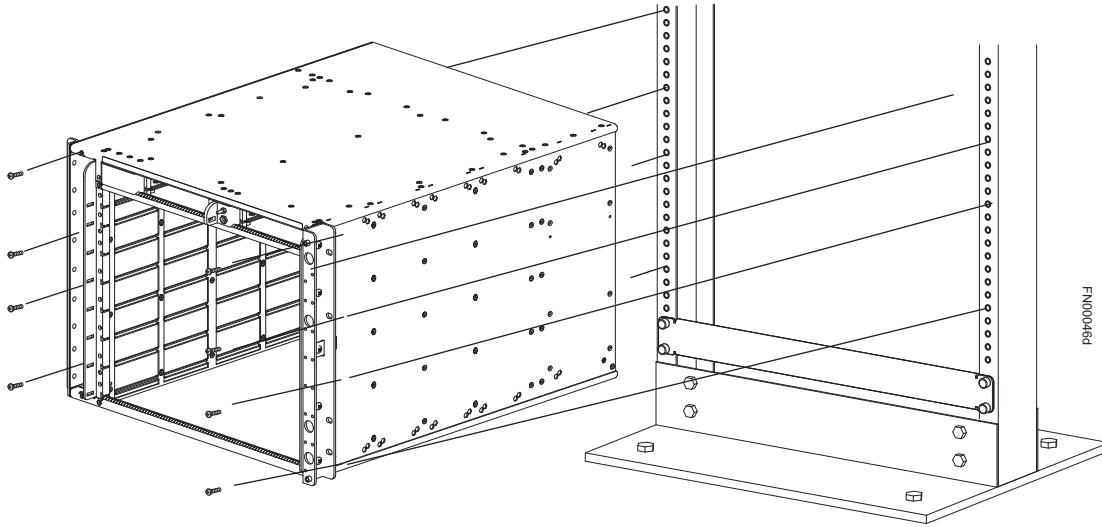

For 19-inch mid mount and 23-inch mid mount brackets, refer to the documentation included with those brackets.

Installing the Chassis into an Equipment Cabinet

Prior to installing the E300 into an equipment cabinet, make sure that there is adequate space for proper ventilation, access to cables, and access for maintenance. With the chassis installed in a cabinet, there must be a minimum of six inches (16 cm) between the chassis sides and the cabinet walls.

To install a chassis into an equipment cabinet:

Step	Task
1	At the desired location in the rack, orient the equipment rack bar with the arrows pointing up. The smooth side of the bar should face outward.
2	Using the mounting screws provided with your rack, attach the bar to the rack (see Figure 4-1).
3	Using a hand cart, pallet jack, or forklift, align the rack-mount holes with the equipment rack hole, situating the chassis on top of the equipment rack bar.
4	Using the screws provided with the cabinet, insert and tighten the screws into the chassis rack mounting and the cabinet.

Installing Power Modules

This chapter contains the following major sections:

- Installing AC Power Modules
- [Installing DC Power Entry Modules on page 22](#)
- [Power Supply and Fan Operability Test on page 27](#)

The E300 system requires a minimum of one DC Power Entry Module (PEM) or a minimum of two AC Power Supplies (see [AC and DC Power on page 14](#)).

 **WARNING:** The E300 must contain only one type of power module—AC or DC.

 **WARNING:** Electrostatic discharge (ESD) damage can occur when components are mishandled. Always wear an ESD-preventive wrist or foot-heel ground strap when handling chassis components.

Installing AC Power Modules

The E300 AC Power Supply Module is capable of operating at either 100 VAC or 220 VAC. If the E300 is connected to a 100 VAC power supply, three power supply modules are required, or four power supply modules are required for power supply redundancy.

If the E300 is connected to a 220 VAC power supply, two power supply modules are required, three power supply modules are required for power supply redundancy, and four power supply modules are required for full facility redundancy.

For full facility redundancy, each power supply must be attached to an independent power source with a dedicated circuit breaker sized in accordance with your local building and electrical safety codes. To comply with safety agency and emission requirements, a power supply blank cover must be inserted into any unused power supply slot.

 **CAUTION:** Before removing and replacing a power supply module, determine if the E300 is in full facility redundancy or non-redundant power. Operating in non-redundant power will require a complete system power off when removing and replacing a power supply.

AC Power Requirements

Parameters	Specifications
Nominal Input Voltage	100 - 120 VAC Requires a minimum of 3 Power Supplies Installed
	200 - 240 VAC Requires a minimum of 2 Power Supplies Installed
Maximum AC Power Supply Input	10 A @ 100 VAC per module
	7 A @ 200 VAC per module
Maximum System Power Input	4.80 KVA @ 100 VAC
	4.60 KVA @ 220 VAC

AC Power Cord Requirements

Each AC power supply is shipped with a Dell Force10-approved AC power cord and only that cord should be used to connect the AC power supply to the appropriate AC outlet. The power source end of the power cord must have an appropriately sized plug that complies with your local electrical codes. Conductor size must also conform to your local electrical codes.

CAUTION: The power cord is the main power disconnect device; ensure that the socket-outlet is located/installed near the equipment and is easily accessible.

The following are Dell Force10 supplied plug types. All power plugs must comply with local codes. Check with your Dell Force10 representative to purchase cords or plugs for your system.

- EU: CEE7/7
- UK: CEE7/7, UK plug
- SWZ: CEE7/7
- JAP: C14, C20, NEMA 5-15, L5-20
- JAP 220: NEMA 6-20, L6-20
- US: C14, C20, NEMA 5-15, L5-20
- US 220: NEMA 6-20, L6-20

CAUTION: The power cord is the main power disconnect device; ensure that the socket-outlet is located/installed near the equipment and is easily accessible.

Figure 5-1. AC Power Supply Locations

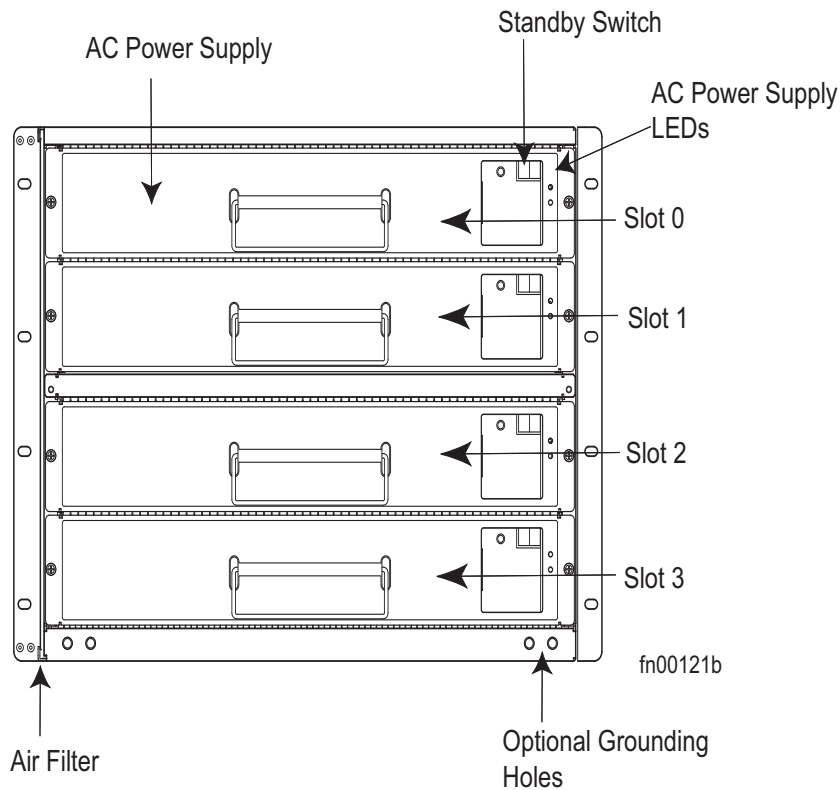

The E300 contains four power supply slots in the rear of the chassis (Figure 5-1).

Each AC power supply contains two LEDs: Status and AC. Table 5-1 describes the LEDs.

Table 5-1. AC Power Supply LEDs

LED	Description
Status (upper LED)	Green: no fault detected; unit on and functioning properly Unlit: unit not supplying power to the system; unit off or in standby mode
AC (lower LED)	Green: line voltage within range; operating normally; unit on or in standby mode Unlit: unit not operating or no power applied

Installing an AC Power Supply

To install an AC power supply:

Step	Task
1	<p>Toggle the Standby Switch of the power supply to the standby position, as shown in the image here.</p> <p>NOTE: If the E300 is already operating, you can insert a new power supply without shutting down the E300.</p>
2	<p>Slide the power supply into any open power supply slot. See Figure 5-1 for correct orientation.</p> <p>CAUTION: Fill all four power supply slots with power supplies or filler blanks before tightening the power supply screws. Doing this ensures that each power supply is aligned correctly. Ensure power supplies are properly aligned prior to engaging the captive screws. Doing this will reduce the likelihood of damaging screws or chassis. It may be necessary to manually align the power supplies prior to tightening.</p>
3	<p>Start the two captive screws of each power supply by hand before tightening them all.</p> <p>CAUTION: Tighten the screws with a #2 Phillips screwdriver. Use no more than five inch-pounds of torque (light torque with a manual screwdriver). Use of power drivers can damage screws or chassis.</p>
4	<p>Plug the AC power cord into the AC power inlet in the face of the power supply.</p>
5	<p>Plug the AC power cord into an AC power outlet.</p>
6	<p>Toggle the standby switch of the power supply to the On position.</p>

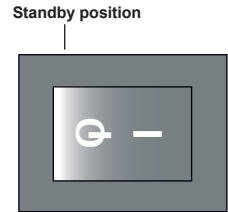

NOTE: If there is a failure in the AC Power Supply, it must be replaced. Power modules are not field serviceable.

Installing DC Power Entry Modules

The E300 supports a minimum of one DC PEM. You must have only one type of power module in the chassis; you cannot install a mixture of power modules. For redundant power, install two DC PEMs. To comply with safety agency and emission requirements, a blank cover must be inserted into any unused power slot.

Figure 5-2. DC PEM Locations

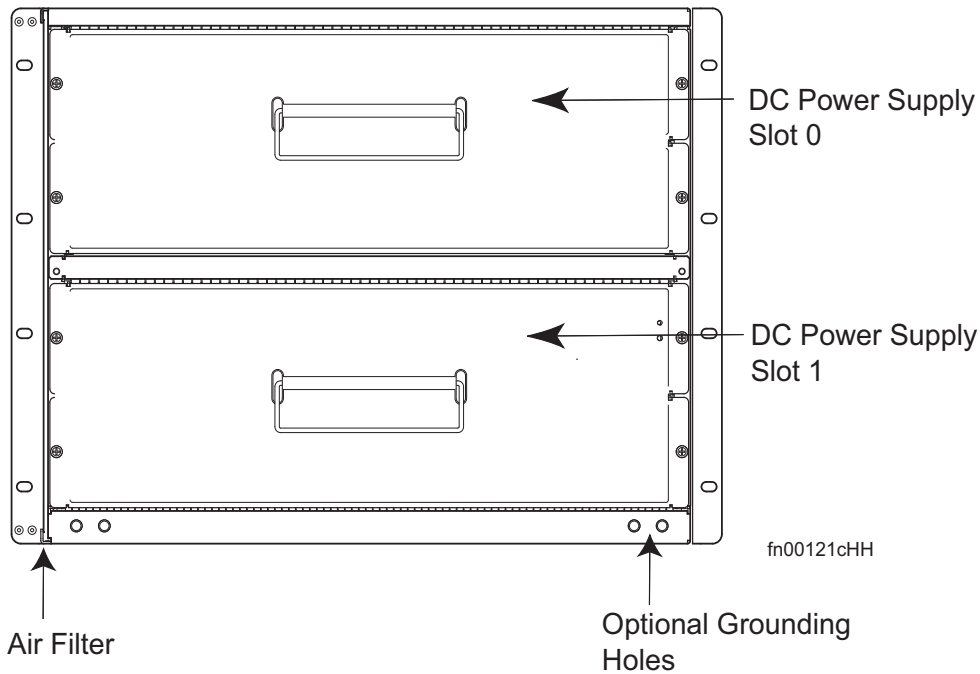

DC Requirements

Maximum Power Dissipation	2400W
Maximum DC PEM Input Current	60A

Redundancy

For full facility redundancy, install two DC PEMs where each PEM must be attached to an independent power source with a dedicated circuit breaker sized in accordance with your local building and electrical safety codes.

Cable and Connector Requirements

You must provide your own cables to connect to a remote power source (a circuit breaker panel, for example) in your equipment rack or facility. Cables must be sized to meet the following criteria:

- Rated for 60A service to allow for a fully loaded E300 system per NEC in the United States or internationally, per local safety codes.
- Limit voltage drop across the cable length to 0.5V or less.

Before you make the cable connections, apply a coat of anti-oxidant paste to unplated metal contact surfaces. File unplated connectors, braided straps, and bus bars to a shiny finish. It is not necessary to file and coat tinned, solder-plated, or silver-plated connectors or other plated connection surfaces, such as those on the PEM studs.

NOTE: Please take precautions against over-tightening the screws or nuts on this device.

LED Status



Status	Green—no fault detected Amber— under voltage Unlit—circuit not energized or circuit breaker open
Pwr In OK	Green—no fault detected Amber— polarity of (+) and (-) are reversed in external cables Unlit—no power or power is under voltage

Removing a DC PEM

The left chassis PEM slot is labelled “0” and the right chassis PEM slot is labelled “1”. For full redundancy, each PEM must be attached to a dedicated circuit breaker. For example, PEM “0” connects to circuit breaker “0” and PEM “1” connects to circuit breaker “1”.

⚠ WARNING: Prevent exposure and contact with hazardous voltages. Do not attempt to operate this system with the safety cover removed.

Step	Task
1	Switch the Over Current Protector (located on the PEM front panel) to the OFF position.
2	Turn off power to the PEM. Ensure that the remote power source is in the OFF position and that the PEM Status LED and Pwr In OK LED are off.
3	Loosen the retaining screw and remove PEM safety cover (see Figure 5-3).
4	Disconnect power cables attached to the PEM.
5	Slide the PEM out of the slot.
6	If you are not replacing the PEM, replace the empty slot with two blank panels.

Installing a DC PEM

Step	Task
1	Turn the remote power source (the circuit breaker panel) to the OFF position.
2	Turn the over current protector (located on the PEM front panel) to the OFF position.
3	Loosen the PEM safety cover retaining screw and remove the cover (Figure 5-3).

Figure 5-3. Removing the PEM Safety Cover

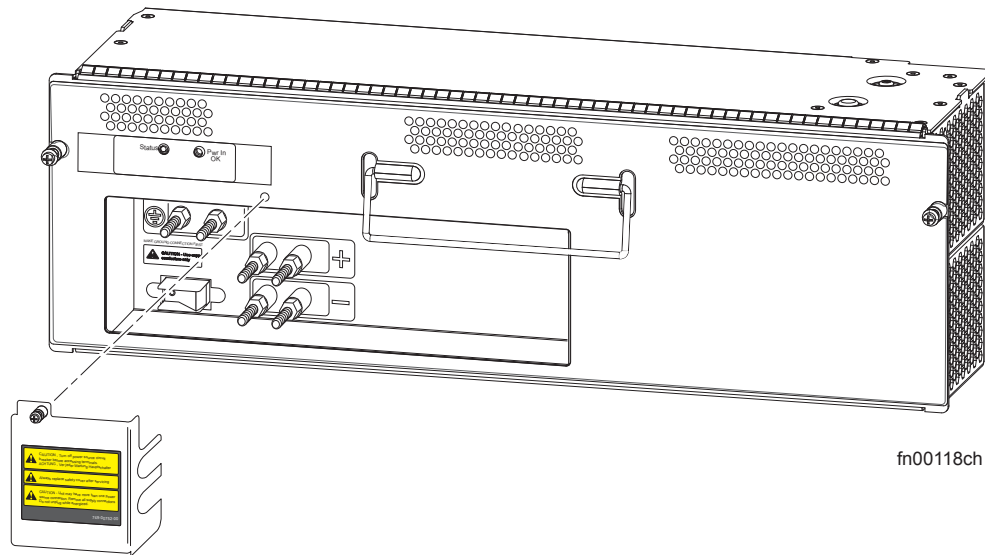

Step	Task (continued)
4	<p>Slide the PEM into power slot 0 or 1 (Figure 5-2).</p> <p>CAUTION: Fill all four power supply slots with power supplies or filler blanks before tightening the power supply screws. Doing this ensures that each power supply is aligned correctly. Ensure power supplies are properly aligned prior to engaging the captive screws. Doing this will reduce the likelihood of damaging screws or chassis. It may be necessary to manually align the power supplies prior to tightening.</p> <p>If you are only installing one PEM, replace the empty slot with two blank panels. (CC-E300-BLNK-PWR.)</p>
5	<p>Start the two captive screws on each power supply by hand before tightening them all.</p> <p>CAUTION: Tighten the screws with a #2 Phillips screwdriver. Use no more than five inch-pounds of torque (light torque with a manual screwdriver). Use of power drivers can damage screws or chassis.</p>

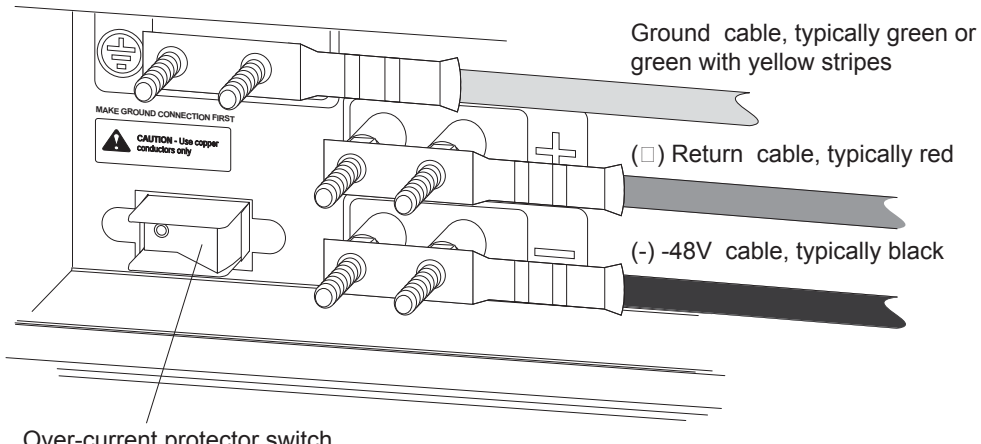
Step	Task (continued)
6	<p>Secure the chassis ground connection:</p> <p>⚠ WARNING: You must complete the ground connection before proceeding with the PEM installation.</p> <p>Locate the chassis ground connector studs on the PEM front panel (see Figure 5-4). The two studs on the upper left are the ground connection.</p> <p>Remove all nuts and washers from the two ground studs.</p> <p>Apply a coat of anti-oxidant paste to the connector studs.</p> <p>Install the grounding cable. This cable is typically green or green and yellow.</p> <p>🔧 NOTE: Termination points require UL-listed 2-hole lug with 1/4-inch holes on 3/4-inch spacing.</p> <p>Replace the two washers and nuts on the studs.</p> <p>Secure the nuts with a nut driver or torque wrench (not to exceed 4 ft/lbs).</p> <p>Connect the opposite end of the grounding cable to the appropriate nearest grounding.</p>
7	<p>Remove the outer nut and washer from each of the remaining studs.</p>
8	<p>Connect the -48 VDC and Return cables from each PEM to the remote power sources.</p> <p>Verify that the remote power source is in the OFF position.</p> <p>Locate the appropriate studs on the PEM front panel. The two top studs are the return (+) connection. The cable attached to these studs is typically red. The two bottom studs on the PEM are the -48 VDC (-) connection. The cable attached to these studs is typically black.</p> <p>🔧 NOTE: Power cables must be terminated only with a UL-listed 2-hole lug to accommodate 1/4-inch studs with 3/4-inch spacing.</p> <p>Apply a coat of anti-oxidant paste to the connector studs.</p> <p>Replace the washers and nuts on the studs.</p> <p>Route the terminated cables out toward the rack rail (Figure 5-4).</p> <p>Secure the nuts with a nut driver or torque wrench (not to exceed 4 ft/lbs).</p>
<p>Figure 5-4. DC PEM with Cables Installed</p>  <p>The diagram shows a front panel of a DC Power Entry Module (PEM) with several terminal studs. On the left, there is a ground connection terminal with a ground symbol. Below it is a label that reads 'MAKE GROUND CONNECTION FIRST' and 'CAUTION - Use copper conductors only'. To the right of the ground terminal are two rows of terminal studs. The top row has two studs, with a '+' sign above them, and is labeled 'Return cable, typically red'. The bottom row has two studs, with a '-' sign below them, and is labeled '(-) -48V cable, typically black'. A ground cable is shown connected to the top-left terminal. Below the panel, an 'Over-current protector switch' is shown. Labels with leader lines point to the ground cable, the return cable, the -48V cable, and the over-current protector switch.</p>	
9	<p>Replace the safety cover and tighten the captive screw with a #2 Phillips screwdriver.</p>
10	<p>Turn the Over Current Protector to the ON position (Figure 5-4).</p>
11	<p>Turn the remote power source (the circuit breaker panel) to the ON position.</p>

Power Supply and Fan Operability Test

After you have completed the fan tray and power supply installation, verify their operability by supplying power to the chassis and verifying the status LEDs.

 **NOTE:** If there is an AC Power Supply or DC PEM failure, the entire unit must be replaced. There are no field serviceable parts inside the AC Power Supply or DC PEM unit.

Before you begin this power test, inspect your equipment rack and chassis. Verify that:

- Each AC power supply or DC PEM is properly installed in the correct slots.
- Your power cables connect to an appropriate AC outlet or DC supply in a manner that complies with your local electrical codes. For DC systems, a Main Disconnect must be provided.
- On the DC PEM(s), use a voltage meter to verify power on the cables. Also verify that the Voltage LED is green.
- A power supply blank is installed in any empty slot.
- The fan tray is installed

 **WARNING:** Prevent exposure and contact with hazardous voltages. Do not attempt to operate this system without the safety cover provided with each DC PEM.

To test the power supplies and the fan tray:

Step	Task
1	With the fan tray and either AC power supplies or DC PEMs installed, power on the system. <ul style="list-style-type: none">• if AC Power Supplies are installed, flip on each switch (located on the front of the AC Power Supply) to the ON position; or• if DC PEMs are installed, flip the Over Current Protector (located on the PEM front panel) to the ON position.
2	In a DC PEM, the Status LED should be green. In an AC Power Supply, the top Input AC and Output DC LEDs should be green. If these LEDs are not lit or the Status LED is amber on a DC PEM, check that the unit is properly installed. Verify the power source. If the LEDs remain unlit, power off all modules and replace the unit.
3	The fan tray LED should be green (online). Verify that air is flowing through the chassis. If the fan tray is not operating properly or air is not flowing through the chassis, power off the chassis at the remote power source. Ensure that the fan tray is properly installed. Verify the remote power source. If the fan tray LED remains unlit, replace the fan tray.
4	After you have verified the power and fan operability, power off the chassis to continue the installation process. <ul style="list-style-type: none">• for DC PEMs, de-energize the Main Disconnect and flip the Over Current Protector to the OFF position.• for AC Power Supplies, flip the switch to the OFF position and disconnect the power cords. Verify that the LEDs are not lit.

Installing E300 Fan Tray

⚠ WARNING: To ensure proper temperature and airflow control, the fan tray must always be installed. Access the fan tray from the front of the chassis. The fan tray contains 16 fans that run at a constant speed.

Figure 6-1. Inserting the Fan Tray

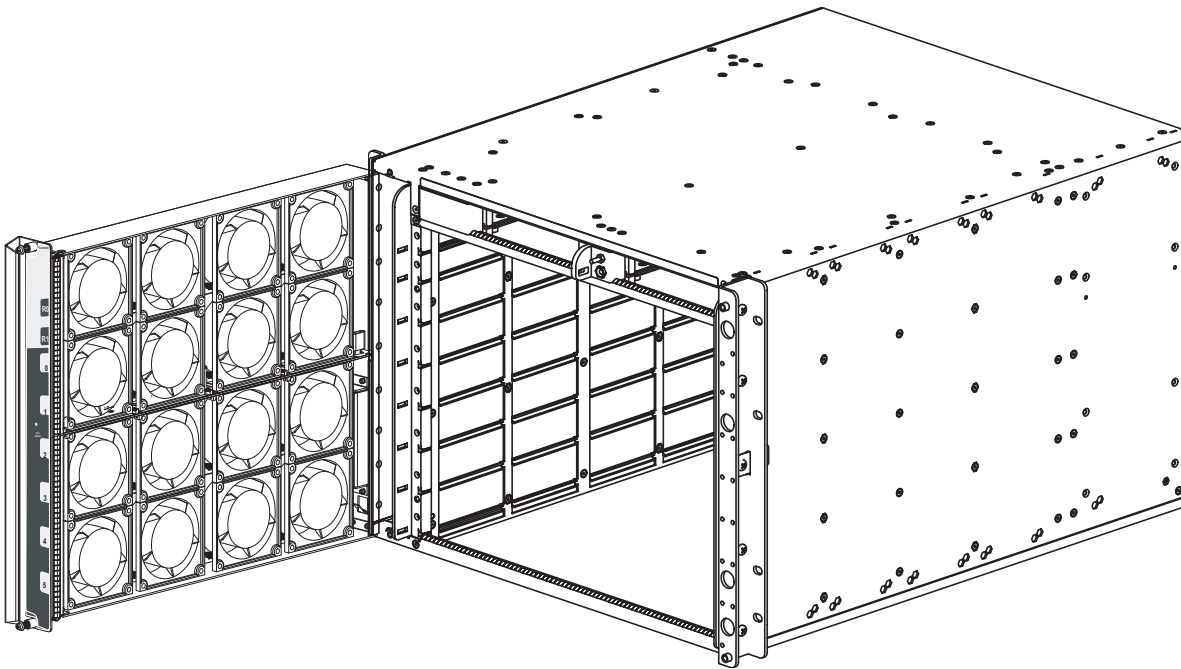

To install the fan tray:

Step	Task
1	Slide the connector end into the fan slot (located in the front of the chassis see Figure 6-1).
2	Gently push on the front of the tray until it stops.
3	Using a #2 Phillips screwdriver, secure the fan tray into place by tightening the screws at the top and bottom of the fan tray.

For information on returning a fan tray to Dell Force10, see [Requesting a Hardware Replacement on page 66](#).

Installing RPMs, Line Cards, and SFMs

The E300 System accommodates six line cards, two Route Processor Module (RPMs), and two Switch Fabric Modules (SFMs).

RPMs

The E300 system requires the installation of at least one RPM, although two are recommended for redundancy. RPMs are designed to be installed in either the R0 or R1 slot. Do not force RPMs into line card slots. RPMs are keyed differently than line cards to prevent improper installation.

You can hot-insert a second RPM into a running system without performance interruption or software intervention. A second RPM for redundant functionality provides uninterrupted operability if the system transitions from the active RPM to the standby RPM. The standby RPM constantly performs updates and receives the same configuration information received by the active RPM. The standby RPM also performs diagnostics on its subsystems. In the event of a switch over, the standby RPM immediately takes over and resumes the control activities that the active RPM was performing. [Installing a Second RPM on page 32](#) provides more information on the second RPM.

You can hot-insert a second RPM into a running system without performance interruption or software intervention. A second RPM for redundant functionality provides uninterrupted operability if the system transitions from the active RPM to the standby RPM. The standby RPM constantly performs updates and receives the same configuration information received by the active RPM. The standby RPM also performs diagnostics on its subsystems. In the event of a switchover, the standby RPM immediately takes over and resumes the control activities that the active RPM was performing. [Installing a Second RPM](#) provides more information on the second RPM.

The RPM Major and Minor Alarm LEDs are controlled by software that sets the threshold levels for triggering the different alarm stages.

Blank Panels

 **CAUTION:** To ensure clean air and emission integrity (EMI), install blank panels for RPMs and line cards slots not in use. Always replace cards or blank panel immediately.

Blank panels for RPMs and line cards must be installed in empty slots to control airflow. Blank panels are shipped with the system to ensure that all chassis slots are installed with operational modules or blanks. The blank panels do not have board components or connector pins. Align the blank with the guides and gently slide toward the backplane.

Unpacking Cards

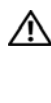
 **WARNING:** Electrostatic discharge (ESD) damage can occur when components are mishandled. Always wear an ESD-preventive wrist or foot-heel ground strap when handling RPMs, SFMs, or line cards. Place RPMs, SFMs, and line cards on an antistatic surface when they are not installed.

WARNING: Do not supply power to your E300 system until the PEM and fan tray are installed and verified, and RPMs, SFMs, and line cards have been installed.

Installing the RPMs and Line Cards

CAUTION: Use of controls or adjustments or performance of procedures other than those specified herein may result in hazardous laser exposure.

Figure 7-1. Installing Line Cards and RPMs into the E300

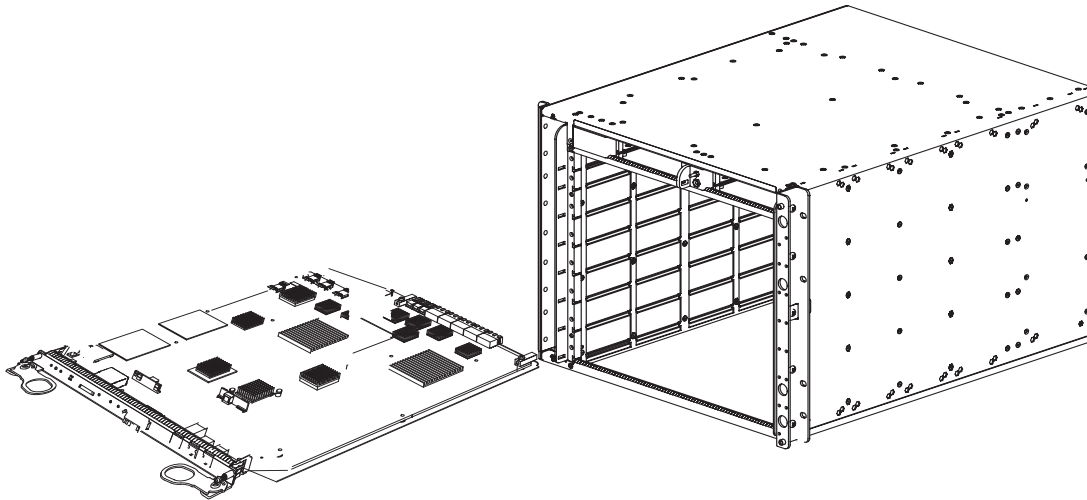

Line cards are hot-swappable.

To install line cards or RPMs:

Step	Task
1	Hold the card by the edges. Avoid touching the printed circuit board and connector pins. Extend the left and right card levers before you insert the card into the slot. Align the card with the guide and gently slide it into the slot until you feel the connectors engage with the chassis backplane.
2	Rotate the levers to seat the backplane connectors and line card in place.
3	Secure card and blanks in place by tightening the left and right captive screws on each card.
4	Follow the same installation procedure for the remaining cards and slots.

Installing a Second RPM

CAUTION: If your system contains two RPMs, both RPMs must contain the same software image.

Install a second RPM either before the system is powered on or after the Primary RPM is up and stable. After the second RPM is installed, wait several seconds until the connection between the two RPMs is established before configuring any commands. Below is an example of the messages that should appear:

```
%POLLMGR-2-ALT_RPM_STATE: Alternate RPM is present
```

%IRC-6-IRC_COMMUP: Link to peer RPM is up

%RAM-6-RAM_TASK: RPM1 is in Standby State.

Once the link between the two RPMs is established, copy the running configuration to the startup configuration.

RPM Label and LEDs

Table 7-1. RPM Front Panel and LED Descriptions

Section	Label	Description
Management	Console Port	Use this RJ-45 jack for the initial system boot, as well as system configuration and monitoring.
	Auxiliary Port	Use this RJ-45 serial auxiliary port for modem connection
	10/100 Ethernet	Use this nonroutable Ethernet port to download images and manage the system, for example, FTP and Telnet operations. This port is provisioned with an RJ-45 jack. Port LEDs: L: Green: link is up. A: Green: activity on port
Alarms		Use the relay contacts to connect a remote alarm indicator to monitor alarm status. The top three contacts (next to the red bar) are for Major alarms and the bottom three contacts (next to the yellow bar) are for minor alarms. NC - Normally Closed C - Common NO - Normally Open
	Major LED	Red: a critical condition exists (such as a severe over temperature condition). See Appendix C, Alarms, on page 57 for more information. Unlit: no major alarm conditions.
	Minor LED	Amber: a serious condition exists (such as a single fan failure or a line card failure). See Appendix C, Alarms, on page 57 for more information. Unlit: no minor alarm conditions.
	ACO/LT Button	Audible alarm Cut Off/Lamp Test (ACO/LT) button allows you to test the operability of LEDs to verify that they are able to light. Pressing this button temporarily illuminates the LEDs on the RPM. If you press the ACO/LT button when an alarm LED is lit, the alarm relay contacts are reset until the next alarm event.
Flash	Slot	Use the multimedia card (external flash memory card) slot to store and retrieve boot and system images.
	In Use LED	Green: flash memory card is in the process of a read or write process. Do not remove the flash card when the In Use LED is lit. Unlit: not in use.
	PS0, PS1, PS2, PS3 LEDs	Indicates if the AC power supplies (located in the rear of the chassis) are installed and operational. Green: AC power supply is operational Unlit: AC power supply not installed or not operational.

Table 7-1. RPM Front Panel and LED Descriptions (continued)

Section	Label	Description
	PEM0, PEM1 LEDs	Not Supported
	Primary LED	Indicates that this RPM is the Primary RPM. Green: primary Unlit: standby
	Reset Button	To reset the RPM, depress the button by inserting a small object, such as a pen tip.
	Status LED	Green: operational Amber: fault detected Flashing green: booting Unlit: in standby mode or power is off

Line Card LEDs

Line card LEDs are described in the documentation specific to each line card. Refer to the installation documentation that came with the card for to understand LED appearance and meaning.

Expandable Cable Management Bracket

The E300 chassis cable management bracket ([Figure 7-2](#)) manages your copper, fiber optic line cards and auxiliary cables to RPMs. Space is provided for approximately 48 CAT5 cables per line card slot. In the standard configuration, wire-ties are used to secure the cabling.

Figure 7-2. Using the Expandable Cable Management Bracket

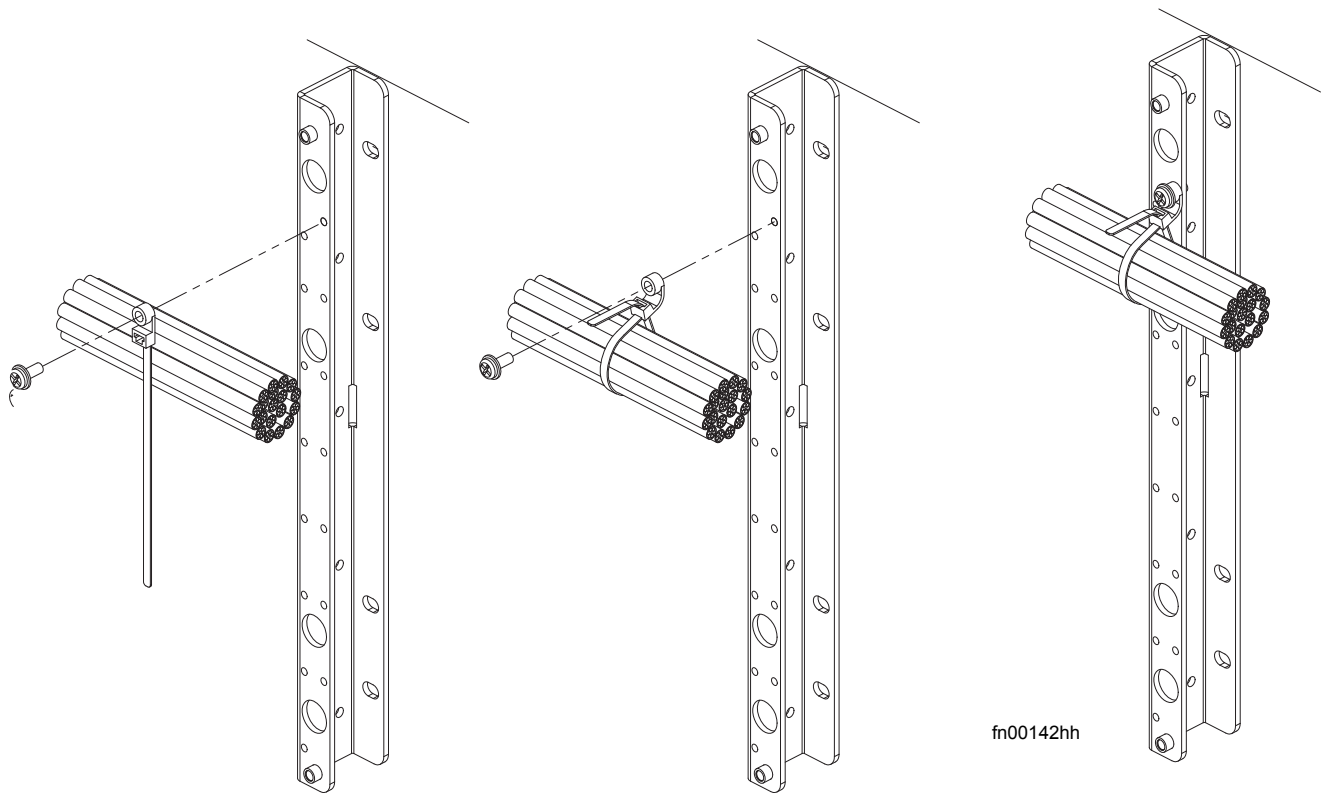

To use the cable management system:

Step	Task
1	Route cables, to the right, across the cable bracket.
2	Thread cables horizontally through the wire-tie loops.
3	Tighten the wire-ties, as appropriate, to your cable bundles. Do not exceed the recommended minimum of a 1.5 bend radius for fiber optic cables.
4	Using the screws provided with the wire-tie loops, insert the screw into the eye of the wire-tie and secure the wire-tie bundle to the mounting bracket.

Installing Switch Fabric Modules (SFMs)

Two SFMs are required for the E300 system to operate optimally. The system operates at non-line rate if only one SFM is installed and operational.

Figure 7-3. SFM

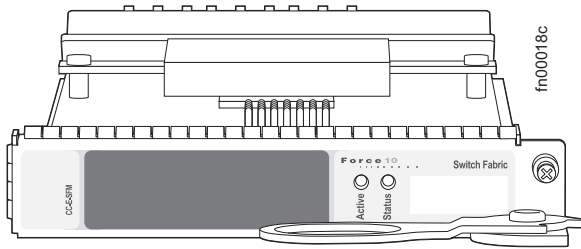
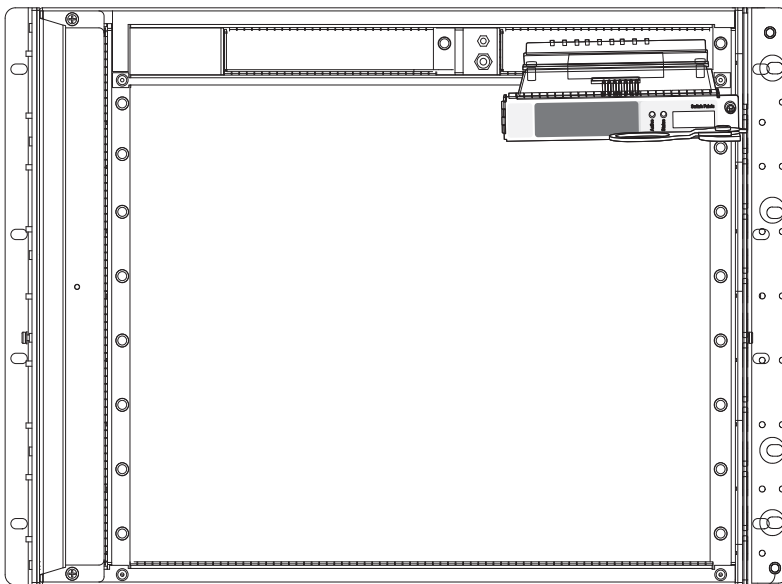

Table 7-2 describes the SFM front panel and LEDs.

Table 7-2. SFM Front Panel and LED Descriptions

LED	Description
Active	Green: active and passing traffic Unlit: in standby mode
Status	Flashing Green: booting Green: operational Amber: fault detected Unlit: no power

Figure 7-4. Installing an SFM



fn00128a

To install SFMs:

Step	Task
1	Hold the card by the edges. Avoid touching the printed circuit board and connector pins. Extend the card lever before you insert the card into the slot. Align the card with the guide and gently slide it into the slot until you feel the connectors engage with the chassis backplane.
2	Rotate the lever to seat the backplane connectors and card in place.
3	Secure each SFM in place by tightening the captive screw.
4	Repeat steps 1 through 4 for the other SFM.

RPM Ports and Cables

The RPM contains three ports, which are labeled and described as:

- **Console.** A Universal Asynchronous Receiver/Transmitter (UART) port with an RJ-45 jack is used for system configuration and monitoring. Modem connections are not supported on the Console.
- **Auxiliary.** A UART port with an RJ-45 port allows modem access to the E300 system from a remote location.
- **10/100 Ethernet.** A 10/100 Ethernet port is the Management port, which is a channel to download images and manage the system, as well as FTP and Telnet operations. You must provide a RJ-45 Ethernet cable to connect to the Ethernet receptacle.

Connecting the Console and Auxiliary Ports

 **NOTE:** Attach an ESD-preventive wrist strap and connect the leash to the ESD connection on the front of the E300 chassis. Always wear an ESD-preventive wrist or foot-heel ground strap when handling components.

The console and auxiliary ports are asynchronous serial ports. If you connect a device to these ports, it must be capable of asynchronous transmission. Your terminal or terminal emulation mode must be set to VT100 with the following settings:

- 9600 baud rate (to avoid autobaud input, the default is set to a 9600 bps baud rate)
- No parity
- 8 data bits
- 1 stop bit
- Window Terminal Emulator option set to **NO**
- 24 lines X 80 characters
- No flow control (console port only)
- Hardware flow control (RTS/CTS) (for auxiliary port only)

Cable and Adapter Pin Assignments

Use the E300 System Console port on the RPM to connect to a terminal port, PC serial port, or a terminal server to configure and monitor your system. Use the E300 Auxiliary port on the RPM to connect to a modem.

Both the Console and Auxiliary port are RJ-45 ports.

[Figure 8-1](#) displays the pinouts in an RJ-45 port.

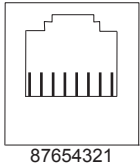
Figure 8-1. Pinouts for an RJ-45 Connector End of Adaptors

[Table 8-1](#) displays the RJ-45 console port pin assignments. [Table 8-2](#) displays the RJ-45 auxiliary port pin assignments.

The table below displays the RJ-45 console port pin assignments.

Table 8-1. Console Port (RJ-45) Pin Assignments

Pin	Signal	Input/Output
1	NC (unused)	-
2	DTR	Output
3	TxD	Output
4	GND	-
5	GND	-
6	RxD	Input
7	DSR	Input
8	NC (unused)	-

The table below displays the RJ-45 auxiliary port pin assignments.

Table 8-2. Auxiliary Port (RJ-45) Pin Assignments

Pin	Signal	Input/Output
1	RTS	Output
2	DTR	Output
3	TxD	Output
4	GND	-
5	GND	-
6	RxD	Input
7	DSR	Input
8	CTS	Input

Accessing the Console with a DB-9 Adapter

You can connect to the console using a RJ-45 to RJ-45 rollover cable and a RJ-45 to DB-9 female DTE adapter (labeled “TERMINAL”) to a terminal server (for example, PC). [Table 8-3](#) lists the pin assignments.

You can connect to the console using a RJ-45 to RJ-45 rollover cable and a RJ-45 to DB-9 female DTE adapter (labeled “TERMINAL”) to a terminal server (for example, PC). The table below list the pin assignments.

Table 8-3. Pin Assignments Between the E300 Console and a DTE Terminal Server

E300 System Console Port	RJ-45 to RJ-45 Rollover Cable		RJ-45 to DB-9 Adapter	Terminal Server Device
	RJ-45 pinout	RJ-45 Pinout	DB-9 Pin	Signal
RTS	1	8	8	CTS
DTR	2	7	6	DSR
TxD	3	6	2	RxD
GND	4	5	5	GND
GND	5	4	5	GND
RxD	6	3	3	TxD
DSR	7	2	4	DTR
CTS	8	1	7	RTS

Accessing the Console with a DB-25 Adapter

You can connect to the console using a RJ-45 to RJ-45 rollover cable and a RJ-45 to a DB-25 female DTE adapter. [Table 8-4](#) lists the pin assignments.

You can connect to the console using a RJ-45 to RJ-45 rollover cable and a RJ-45 to a DB-25 female DTE adapter. The table below lists the pin assignments.

Table 8-4. Pin Assignments Between E300 Console and DB-25 Adapter

E300 System Console Port	RJ-45 to RJ-45 Rollover Cable		RJ-45 to DB-25 Modem Adapter	Terminal Server Device
	RJ-45 Pinout	RJ-45 Pinout	DB-25 Pinout	Signal
RTS	1	8	5	CTS
DTR	2	7	6	DSR
TxD	3	6	3	RxD
GND	4	5	7	GND
GND	5	4	7	GND
RxD	6	3	2	TxD
DSR	7	2	20	DTR
CTS	8	1		RTS

Accessing the Auxiliary Port by Modem

You can access the auxiliary port using a dial-up modem using a RJ-45 to RJ-45 rollover cable and a RJ-45 to a DB-25 male DCE adapter (labeled “MODEM”). [Table 8-5](#) lists the pin assignments.

You can access the auxiliary port using a dial-up modem using a RJ-45 to RJ-45 rollover cable and a RJ-45 to a DB-25 male DCE adapter (labeled “MODEM”). The table below lists the pin assignments.

Table 8-5. RJ-45 to DB-25 Adapter Pin (Modem) Assignments

E300 System Auxiliary Port	RJ-45 to RJ-45 Rollover Cable		RJ-45 to DB-25 Modem Adapter	Modem
Signal	RJ-45 Pinout	RJ-45 Pinout	DB-45 Pinout	Signal
RTS	1	8	4	RTS
DTR	2	7	20	DTR
TxD	3	6	3	TxD
GND	4	5	7	GND
GND	5	4	7	GND
RxD	6	3	2	RxD
DSR	7	2	8	DCD
CTS	8	1	5	CTS

Accessing the 10/100 Ethernet Management Port

Configure the 10/100 Ethernet management port, labeled **10/100 Ethernet** on the primary RPM card in order to obtain network access capability, such as downloading a runtime image onto your system. You can connect this port to an Ethernet hub or FastEthernet port on a router.

Table 8-6. 10/100 Ethernet Management Port LEDs

Label	Description
L (Link)	Lit: Link is up. Unlit: No connection
A (Activity)	Lit: Activity on port. Unlit: No activity

Powering Up

This chapter provides instructions for powering up your E300 system once you have installed all the chassis components and made your power and network connections. It covers the following topics:

- [Preparation](#)
- [Supplying Power on page 43](#)
- [Booting to the CLI Prompt on page 44](#)

Preparation

 **NOTE:** Make sure that the switch on the remote power source is in the **OFF** position until you are ready to supply power to the chassis.

Before you supply power to your chassis, Dell Force10 recommends that you re-inspect your equipment rack and chassis.

Verify that:

- The equipment rack is properly secured and grounded.
- The chassis is bolted and secured into your equipment rack.
- Each power supply module (AC or DC) is properly installed and grounded.
- Each power supply module's switch is in the **OFF** position.
- The safety covers are installed on each DC PEM.
- Power cables connect to a compliant remote power source.
- The fan tray is installed and cannot be removed by pulling on the fan tray handles.
- All line cards, RPMs, and SFMs are properly installed and secured.
- All chassis slots are filled. Blank panels and covers are installed in all empty slots.

Supplying Power

To supply power to the E300 system:

Step	Task
1	Energize the remote power source.
2	Flip the switch on the AC power supplies or DC PEM to the ON position.
3	In a DC PEM, the Status LED should be green. In an AC Power Supply, the top Input AC and Output LEDs should be green. If these LEDs are not lit or the Status LED is amber on a DC PEM, check that the unit is properly installed. Verify the power source. If the LEDs remain unlit, power off all modules and replace the unit.

Step	Task
4	The fan tray LED should be green (online). Verify that air is flowing through the chassis. If the fans are not operating properly or air is not flowing through the chassis, power off the chassis at the power module. Ensure that the fan is properly installed. Verify the power source. If the fan impeller LED remains unlit, replace the fan impeller.

To turn the power off on the power modules, use one of the following methods:

- On the DC PEMs, flip the switch to the **OFF** position. Make sure the AC power supplies Status LEDs are not lit.
- On the AC Power Supplies, flip the switch to the **OFF** position and unplug the power cord from the socket on the front of the Power Supply. Make sure the Input AC and Output DC LEDs are not lit (they may flash as they power down.)

Booting to the CLI Prompt

After you supply power to the system, the following should occur:

- The fans should be operating.
- The green (online) fan tray, power module, RPM, SFM, and line card LEDs should be lit and remain lit as long as the system is receiving power and is operational.

When you supply power to the E300 system, the system performs a series of power-on self tests. RPM, line card, and SFM LEDs blink as the diagnostic programs run. No user interaction is required at this point. Observe the process on your console monitor. When the boot process is complete, the card LEDs remain online (green) and the console monitor displays the Command Line Interface (CLI) prompt.

 **NOTE:** Do not press any keys or control sequences at any time during the boot process. Doing so may cause the boot process to terminate.

Booting from the BOOT_USER Prompt

The initial boot operation automatically brings up the system to the runtime CLI. To interrupt the automatic boot process, issue a break key sequence (CNTL-SHIFT 6). The console monitor will display the default BOOT_USER # prompt. Refer to [Appendix A, System Boot, on page 51](#) for instructions to continue the boot process.

Removing and Replacing Components

This section provides instructions for removing and replacing the following E300 components:

- [Removing and Replacing the Fan Tray](#)
- [Removing and Replacing Power Module](#)
- [Removing and Replacing RPMs, Line Cards, or SFMs](#)
- [Removing and Replacing the Air Filter](#)

When a component fails, the E300 System system triggers major or minor alarm LEDs (located on the RPM), sends events to the SNMP trap and show alarms table, disables or changes component Status LEDs or triggers an audible alarm. Refer to [Appendix C, Alarms, on page 57](#) for more information on alarms.

For details on returning components to Dell Force10, see [Requesting a Hardware Replacement on page 66](#).

When a component fails, the E300 System system triggers major or minor alarm LEDs (located on the RPM), sends events to the SNMP trap and show alarms table, disables or changes component Status LEDs or triggers an audible alarm. Refer to [Appendix C, Alarms, on page 57](#) for more information on alarms.

Removing and Replacing the Fan Tray

A fan tray failure or a failure of one fan within the fan tray is recognized by an unlit LED, an SNMP trap, or major alarm event. The failure requires a replacement of the entire fan tray. While you replace the fan tray, the E300 system will operate safely for approximately one (1) minute at an ambient temperature of 95° F (35° C).

To remove and replace the fan tray, you must be able to pull the fan tray completely out of the slot (at least 20 inches).

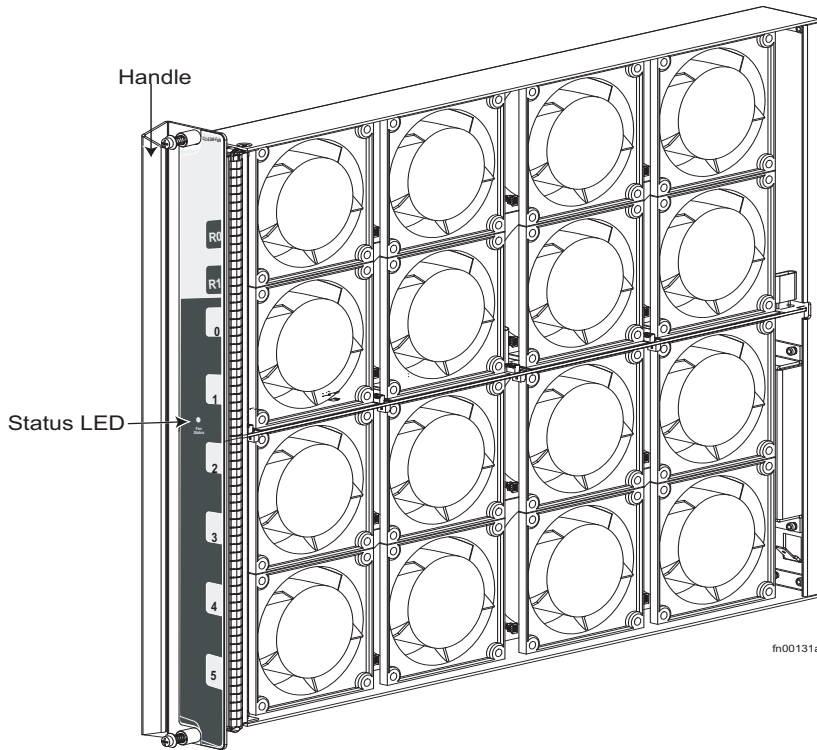
Figure 10-1. E300 Fan Tray

To remove and replace the fan tray:

Step	Task
1	Unscrew the retaining screws at the top and bottom of the fan tray.
2	Grip the handle and pull the fan tray out approximately one inch from the chassis. Wait 30 seconds, until the fan blades stop rotating, then completely remove the fan tray.
3	Insert the fan tray into the chassis. Guide the tray firmly into the slot until it stops and the handle end is flush with the chassis.
4	Secure the fan tray into place by tightening the screws, at the top and bottom of the fan tray, using a #2 Phillips screwdriver.

Removing and Replacing Power Module

If you are operating your E300 chassis with a redundant AC Power Supply, you can install, remove, or replace a power supply without affecting system operation. If you are operating your E300 system with only three Power Supplies (the minimum), you must completely power off the system to replace a power supply.

NOTE: If there is a power module failure (the Status LED is not lit, major alarm LED is lit, and audible alarm sounds from the RPM), the entire unit must be replaced. There are no field serviceable parts inside the unit.

CAUTION: The power supply cord is used as the mains disconnect device, ensure that the socket-outlet is located/installed near the equipment and is easily accessible so that the plug can be disengaged.

To remove an AC Power Supply:

Step	Task
1	Toggle the switch on the AC Power Supply to the OFF position.
2	Disconnect the power cable from the AC power source.
3	Loosen the retaining screws.
4	Pull the AC Power Supply out of the slot.
5	If you are replacing an AC Power Supply, go to Chapter 5, Installing Power Modules, on page 19 . If you are replacing an AC Power Supply, go to Chapter 5, Installing Power Modules . If you are not replacing the AC Power Supply, insert a power module blank filler in the empty slot.

Removing and Replacing RPMs, Line Cards, or SFMs

 **WARNING:** Your E300 system will not send traffic at line rate with only one SFM.

 **WARNING:** Electrostatic discharge (ESD) damage can occur when components are mishandled. Always wear an ESD-preventive wrist or ankle strap when handling RPMs, SFMs, or line cards. Connect the ESD strap to the grounding plug located on the front of the chassis. Place RPMs, SFMs, and line cards on an antistatic surface and anti-static bags when they are not installed.

 **WARNING:** Do not remove a panel blank unless you are ready to install a line card or RPM into that slot. If you remove a card, immediately replace the empty slot with a panel blank. Blanks are required to control airflow and electromagnetic interference.

 **NOTE:** If you operate your E300 without a redundant RPMs, the system enters a software-defined power-down state when you remove the only RPM for replacement.

You can add, replace, or remove E300 modules without interrupting the system power or system operations. RPMs and line cards are hot-swappable.

The E300 System system generates major alarm events for high temperatures (over 75°C for RPMs and SFMs; over 80°C for line cards) and module failures depending on the module and whether or not it is redundant. Minor alarms are generated for component temperatures over 65°C for RPMs and SFMs; over 75°C for line cards. SNMP traps are sent for both alarm types. Refer to [Appendix C, Alarms, on page 57](#) for more details.

You can add, replace, or remove E300 modules without interrupting the system power or system operations. RPMs and line cards are hot-swappable. The E300 System system generates major alarm events for high temperatures (over 75°C for RPMs and SFMs; over 80°C for line cards) and module failures depending on the module and whether or not it is redundant. Minor alarms are generated for component temperatures over 65°C for RPMs and SFMs; over 75°C for line cards. SNMP traps are sent for both alarm types. Refer to [Appendix C, Alarms, on page 57](#) for more details.

If you are *not* operating your system with redundant cards (with only one SFM or one RPM) you must power off your system until the cards are replaced.

To remove and replace E300 RPMs and line cards:

Step	Task
1	Unplug the network interface cables connected to the line card or RPM.
2	Loosen the captive screws and pull the ejector levers simultaneously toward you to disengage the backplane connections.
3	If you are installing a line card, follow these procedures: <ul style="list-style-type: none"> • If you are hot swapping (replacing the line card with the same card type), no additional configuration is required. • If you are installing a different line card type, enter the configure the following commands: no linecard <i>number</i> to remove the old line card configuration where <i>number</i> is a slot number. • If you are replacing the line card with a blank panel, delete the line card information from the configuration by entering: no linecard <i>number</i>
4	Slide the card out of the slot.
5	If you are immediately installing a replacement card, align the new card with the guide and gently slide the card into the slot until you feel the connectors engage with the chassis backplane. The software will detect the new line card and enter it in the running configuration. If you are not planning to install a new card immediately, install a blank panel.
6	Enter the copy running-config <i>file-url</i> command to save the configuration.

To remove and install an SFM:

Step	Task
1	Loosen the captive screws and pull the ejector lever towards you to disengage the backplane connections.
2	Slide the card out of the slot.
3	Hold the SFM by the edges. Avoid touching the printed circuit board and connector pins. Extend the card lever before you insert the card into the slot. Align the new SFM with the guide and gently slide the card into the slot until you feel the connectors engage with the chassis backplane.
4	Rotate the lever to seat the backplane connectors and SFM in place.
5	Secure the SFM in place by tightening the captive screw.

Removing and Replacing the Air Filter

The E300 air filter is hot-swappable. You do not need to turn the power off to the chassis to replace a filter. Filters should be inspected monthly, cleaned, and replaced only if it is damaged. See [Figure 10-2](#).

Figure 10-2. Replacing the Air Filter

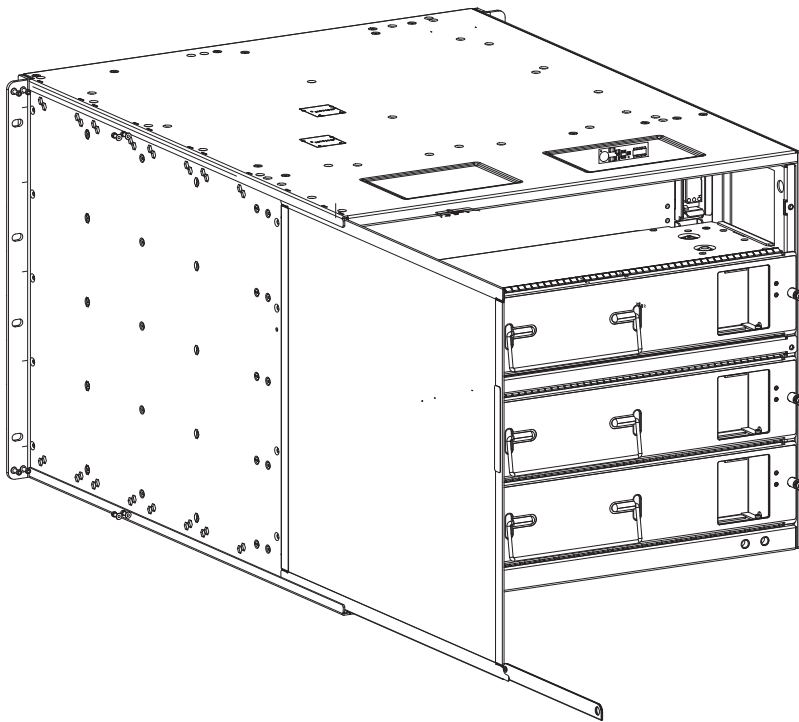

To remove and replace the air filter:

Step	Task
1	Pull the air filter straight out of the chassis.
2	Insert the filter replacement as shown in Figure 10-2 . Guide the filter firmly into the slot until it stops.

System Boot

When you supply power to the E300 system, the system performs a series of power-on self-tests. SFM, RPM, and line card Status LEDs blink during initialization. No user interaction is required as long as the boot process proceeds without interruption. Observe the process on your console monitor. When the boot process is complete, the SFM, RPM and line card Status LEDs remain online (green) and the console monitor displays the command line interface (CLI) prompt, Force10>.

The RPM cards in the E300 system use a Compact Flash card (external flash memory card) to store and retrieve boot and system images. This is the default storage area for the boot files and the startup configuration file. Upon system power up or a system reset, the boot process uses parameters stored in non-volatile random access memory (NVRAM) to boot the system.

Each RPM card is equipped with a slot for an external flash memory card (slot0:). You can copy the image files and configuration files to the external flash device on the *primary* RPM. You can also begin your boot process by accessing a remote server containing the boot image and system image files.

 **NOTE:** The E300 system supports up to a 40-character file name length, up to a 180-character local file path length, and up to a 256-character remote file path length.

For information about the Compact Flash card, refer to [Appendix B, The Compact Flash Card, on page 55](#).

For information about the flash memory card, refer to [Appendix B, The Compact Flash Card, on page 55](#).

Booting from the BOOT_USER Prompt



To get into the BOOT_USER mode, issue a break control sequence (CNTL+^) to interrupt the automatic boot process or you may enter the mode if you experience boot problems. This mode allows you to modify the parameters necessary to manage the boot process. Only console port access is enabled for the BOOT_USER mode.

The BOOT_USER # prompt appears after an autoboot interruption. This is the default boot prompt, not the CLI prompt.

In some display outputs, you can continue the help screen display by pressing ENTER or can stop the output by entering q and then ENTER. You can abbreviate the boot commands by entering only the first letter of a command word. (In the BOOT_USER mode, you cannot press the TAB key to complete commands.) A matching algorithm displays the commands starting with the letter or letters you entered. For example, b displays the commands starting with the letter b, boot change and boot selector. Entering s h displays the syntax help information. All commands are case insensitive.

To configure the chassis from the BOOT_USER prompt use the following commands:

Command	Purpose
help	• Enter help or ? to display a list of available commands and syntax.
or	• Enter syntax help to display syntax information and variable descriptions.
?	

Command	Purpose <i>(continued)</i>
boot change {primary secondary default}	<p>If your configuration displays no preconfigured operating system boot parameters, use the boot change command to edit appropriate fields.</p> <ul style="list-style-type: none"> • The primary operating system boot parameters are used in the first attempt to boot the system. • The secondary operating system boot parameters are used if the primary operating system boot selection is not available. • The default operating system boot parameters are used if the secondary operating system boot parameter selection is not available. The default parameters always reside on the internal flash device (flash:). <p> NOTE: These parameters, as well as other boot parameters, can be modified in the run-time mode.</p> <p>When you enter the boot change command, you are prompted for a response.</p> <ul style="list-style-type: none"> • Enter a new parameter or press the ENTER key (carriage return) to accept the default parameter. • Enter . (period) to clear a field. • Enter - (dash) to edit a field above the current cursor position. <p> NOTE: When you enter a new parameter that extends beyond 80 characters, you cannot use the BACKSPACE key to correct any mistakes. If you make a mistake, you must re-enter the parameter.</p>

```

BOOT_USER # boot change primary

'.' = clear field; '-' = go to previous field

boot device           : flash
file name             : /FTOS-EF-6.1.x.y.bin

BOOT_USER # boot change default

'.' = clear field; '-' = go to previous field

boot device           : flash
file name             : /FTOS-EF-6.1.x.y.bin

BOOT_USER #

```

Command	Purpose <i>(continued)</i>
show bootvar	This command displays the current operating system boot configuration parameters.

```

BOOT_USER # show bootvar

PRIMARY OPERATING SYSTEM BOOT PARAMETERS:
=====
boot device           : flash
file name             : /FTOS-EF-6.1.x.y.bin

SECONDARY OPERATING SYSTEM BOOT PARAMETERS:
=====
No Operating System boot parameters specified!

```

show bootflash	This command displays information about the current boot ROM.
----------------	---------------------------------------------------------------

```

BOOT_USER # show bootflash

GENERAL BOOTFLASH INFO
=====
Bootflash Partition A:
  Forcel0 Networks System Boot
  Copyright 1999-2004 Forcel0 Networks, Inc.
  ROM Header Version 1.0
  Official CP_IMG_BOOT, BSP Release 2.4.0.14
  Created Fri Nov  5 18:22:47 US/Pacific 2004

Bootflash Partition B:
  Forcel0 Networks System Boot
  Copyright 1999-2004 Forcel0 Networks, Inc.
  ROM Header Version 1.0

```

Command	Purpose <i>(continued)</i>
interface management port config 100m	• Use these commands to set the speed and duplex settings for the Management interface. The default setting is full-duplex and auto-negotiation.
interface management port config 10m	• Use the interface management port config show command to view the Management interface's physical settings.
interface management port config auto-negotiate	
interface management port config no auto-negotiate	
interface management port config full-duplex	
interface management port config half-duplex	
interface management port config show	
show interface management ethernet	• Use the show interface management ethernet command to display the IP address and network mask of the management Ethernet port.
interface management ethernet ip address <i>ip-address ip-address-mask</i>	• If the show command output does not display configured IP address information, use the interface management ethernet ip address <i>ip-address ip-address-mask</i> command to set the IP address of the Management Ethernet port for network (ftp/tftp) operating system boot.

```

BOOT_USER # show interface management ethernet
No IP address set for interface management ethernet 0/0!

BOOT_USER # interface management ethernet ip address 1.2.3.4 255.255.0.0
Management ethernet 0/0 IP address: 1.2.3.4 255.255.0.0

```

boot zero {default | primary | secondary}

Delete the boot configuration.

reload

Reload software.

The autoboot program initializes and displays self-test results on the console screen.



NOTE: Do not press break control sequence at any time during the boot/reboot process. Doing so causes the boot process to terminate.

Refer to the *<ItalicText>FTOS Command Line Interface Reference* for BOOT_USER mode commands and commands for run-time modes.

The Compact Flash Card

Each RPM is designed with a slot (slot0:) to accommodate a Compact Flash Card (external flash memory card). You can use the Compact Flash Card to store and retrieve boot and system images. For complex configurations, you can copy your configurations onto the Compact Flash Card and then transfer the configuration to other E300 systems in your network.

NOTE: Use only the Dell Force10 external flash memory card in your E300 System. Additional memory cards can be purchased from Dell Force10.

Inserting the Compact Flash Card

NOTE: Insert the Compact Flash Card either before system boot or after the system has completed its boot and is in run-time mode.

Figure B-1. Inserting the Compact Flash Card in RPM

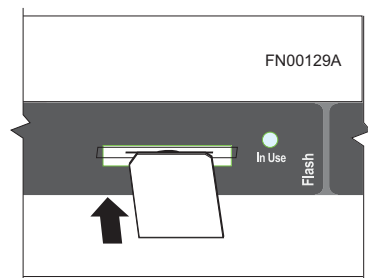

To install the Compact Flash card:

Step	Task
1	Hold the flash card horizontally with the slanted edge on top and the connector end facing the slot. (See Figure B-1)
2	Insert the flash card into the primary RPM flash slot until the card is completely seated with the connectors at the rear of the slot. Do not force the card into the slot. The slot is designed to prevent improper installation. The In Use LED illuminates only during read or write operations.

Removing the Compact Flash Card

To remove the flash memory card:

Step	Task
1	Make sure that the In Use LED is not lit and gently depress the flash card in the slot. The card should partially pop out of the slot.
2	Remove the card and place it in an antistatic bag.

Formatting a Compact Flash Card

New Compact Flash cards must be formatted in the E300 before use.

Flash cards used on systems other than the E300, as well as cards formatted on PCs, must be reformatted in the E300 flash slot before they can be used. Similar to formatting a new diskette, formatting erases all information stored on the flash card.

The Compact Flash supports 100 files. To format the Compact Flash card:

Step	Task
1	Insert the flash card into the flash slot on the <i>primary</i> RPM.
2	In the CLI, enter format slot0:
3	The formatted flash card is ready to use.

FTOS supports up to a 40-character file name length, up to a 180-character local file path length, and up to a 256-character remote file path length.

Refer to the *<ItalicText>FTOS Command Line Interface Reference* for more CLI commands related to the Compact Flash card.



Alarms

The E300 System generates major and minor alarms for the following conditions:

- fan tray status
- power supply status
- RPMs status
- high temperature on RPMs
- line cards status
- high temperature on line cards
- SFMs status
- high temperature on SFMs.

A major alarm is any fault that would render the E300 System non-functional.

A minor alarm is any fault that threatens the operation of the E300 System.

You can monitor alarm conditions on the E300 System system through the console, LEDs, and audible alarms. If you configure the SNMP command (snmp-server enable traps envmon), the FTOS also sends an SNMP trap.

In the E300 System system, alarms are logged for each occurrence, but the system may not send an event log for multiple occurrences. For example, whenever a module exceeds the shutdown threshold, the module shuts down.

If more than one module exceeds the warning or high temperature thresholds within a five minute period, the system generates one event for all effected modules, but alarms are logged for each occurrence. If the modules temperature falls to 5° lower than the warning threshold temperature, the system clears the alarm and an SNMP trap.

Table C-1. Alarm Events and Reporting

Module	Alarm Event	Alarm LED	Reported in event log	Status LED on Module	Audible Alarm?
Fan tray	More than one fan within the module fails or hardware failure in the module	major (red)	major	unlit	yes
AC Power Supplies	Hardware failure in a non-redundant power configuration (3 power supplies)	major (red)	major	unlit	yes
	Hardware failure in a redundant power configuration (4 power supplies)	minor (amber)	minor	unlit	no

Table C-1. Alarm Events and Reporting (continued)

Module	Alarm Event	Alarm LED	Reported in event log	Status LED on Module	Audible Alarm?
Line Card	Hardware failure	major (red)	major	amber	no
	Exceeds high temperature limit	major (red)	major	unlit	yes
	Exceeds warning temperature limit	minor (amber)	minor	green	yes
	Individual interface fails	minor (amber)	reported	amber ^a	no
RPM (Non-redundant Configuration with 1 RPM)					
	Exceeds high temperature limit	major (red)	major	unlit	yes
	Exceeds warning temperature limit	minor (amber)	minor	green	no
	RPM fails but CP is ok	major (red)	major	amber	yes
SFM					
	Exceeds high temperature limit	major (red)	major	unlit	yes
	Exceeds warning temperature limit	minor (amber)	minor	green	no
	Any card fails	major (red)	major	unlit	yes
	Any card removed	major (red)	major	unlit	yes

a. The interface's Link LED is unlit.

AC Power Supplies and Alarms

During system boot, if the redundant power supply (the fourth power supply) is missing or fails, the FTOS does not generate any alarm messages since the minimum configuration of three power supplies is operating. Yet, if a fourth AC power supply is installed, and later one of the four power supplies is removed or fails, the system generates a minor alarm and a message stating that the configuration is non-redundant (%CHMGR-1-MINOR_PS: Minor alarm: power supply non-redundant).

If only three power supplies are installed and one of them fails while the E300 System is operating, the software generates a major alarm and an SNMP trap, lights the major LED, and activates the audible alarm.

System Specifications

The major sections in this appendix are:

- [Chassis Physical Design](#)
- [Environmental Parameters on page 60](#)
- [Power Supplies System Power Requirements on page 60](#)
- [Module Power Requirements on page 61](#)
- [Agency Compliance on page 61](#)
- [Product Recycling and Disposal on page 63](#)

Chassis Physical Design

Parameter	Specifications
Height	14 inches (35.6 cm)
Width	17.4 inches (44.2 cm)
Depth (including cable management brackets)	24 inches (61 cm)
Chassis weight with factory-installed components (backplane and air filter)	90 pounds (approx.) (41 kg)
Weight fully loaded (backplane, air filter, 1 fan tray, 2 SFMs, 2 RPMs, and 6 line cards)	170 pounds (approx.) (77 kg)
Mounting	Integral rack mount strips for front mounting in a standard 19-inch rack. Optional brackets for center mounting in a standard 19-inch and 23-inch rack or cabinet. Optional brackets for front mounting in a 23-inch rack or cabinet.
Rack clearance required	Front: 18-inches (46 cm) Rear: 20-inches (51 cm)
Thermal output:	
• Maximum for fully loaded chassis	2500 W (8500 BTU/hour)
• Normal operating conditions (25 deg.C, -48V-line)	2000 W (6800 BTU/hour)
• Minimum for chassis with one 24-port 1GE line card	800 W (2700 BTU/hour)

Environmental Parameters

Parameter	Specifications
Operating:	
Temperature	40° to 105°F (5° to 40°C)
Maximum altitude	No performance degradation to 10,000 feet (3,048 meters)
Relative humidity	5 to 85 percent, noncondensing
Non-operating:	
Temperature	-40° to 158°F (-40° to 70°C)
Maximum altitude	15,000 feet (4,572 meters)
Relative humidity	5 to 95 percent, noncondensing

Power Supplies System Power Requirements

Table D-1. AC Power System Specifications

Parameter	Specifications
Nominal Input Voltage	100 - 240 VAC 50/60 Hz
Maximum AC Power Supply Input Current (based on 800W output for 100/120V line and 1200W output for 200/240V line.)	7.4 A @ 100 VAC per AC Power Supply
	6.2 A @ 120 VAC per AC Power Supply
	5.2 A @ 200 VAC per AC Power Supply
	4.3 A @ 240 VAC per AC Power Supply
Maximum System Power Input	2.2 KVA @ 100/120 VAC
	2.0 KVA @ 200/240 VAC
Maximum System Power Consumption	2,149 W @ 100/120 VAC
	2,000 W @ 200/240 VAC
Maximum Thermal Output (2,049 W) for 100/120 V	6,989 BTU/hour
Maximum Thermal Output (1,900 W) for 200/240 V	6,483 BTU/hour

Table D-2. DC Power System Specifications

Parameter	Specifications
Nominal Input Voltage	-44 to 60 VDC
Maximum Current Draw (per DC PEM)	60 A
Maximum System Power Consumption	1,740 W
Maximum Thermal Output (1,640 W)	5,596 BTU/hour

Module Power Requirements

Module	Catalog Number	Maximum Watts
SFM	C-E-SFM3	55W
E300 RPM	LC-EF3-RPM	115W
E300 fan tray	CC-300-FAN	85W
DC Power Entry Module	CC-E300--PWR-DC	1400 W
AC Power Supply Unit	CC-E300-1200W-AC	1200 W
12-port Gigabit Ethernet line card with SFPs (LC-E)		W (BTU/hour)
1-port 10 Gigabit Ethernet line card (LC-E)		W (BTU/hour)
12-port 100/1000 BASE T line card (LC-E)		W (BTU/hour)

 **NOTE:** Additional components may be available for your system, other than those included in the above table. Refer to www.force10networks.com for the latest information.

Agency Compliance

The E300 System is designed to comply with the following requirements.

USA Federal Communications Commission (FCC) Statement

This equipment has been tested and found to comply with the limits for a Class A digital device, pursuant to Part 15 of the FCC rules. These limits are designated to provide reasonable protection against harmful interference when the equipment is operated in a commercial environment. This equipment generates, uses, and can radiate radio frequency energy. If it is not installed and used in accordance to the instructions, it may cause harmful interference to radio communications. Operation of this equipment in a residential area is likely to cause harmful interference, in which case users will be required to take whatever measures necessary to correct the interference at their own expense.

Properly shielded and grounded cables and connectors must be used in order to meet FCC emission limits. Dell Force10 is not responsible for any radio or television interference caused by using other than recommended cables and connectors or by unauthorized changes or modifications in the equipment. Unauthorized changes or modification could void the user's authority to operate the equipment.

This device complies with Part 15 of the FCC Rules. Operation is subject to the following two conditions: (1) this device may not cause harmful interference, and (2) this device must accept any interference received, including interference that may cause undesired operation.

Canadian Department of Communication Statement

Industry Canada Class A emission compliance statement

This Class A digital apparatus complies with Canadian ICES-003.

Avis de conformité à la réglementation d'Industrie Canada

Cet appareil numérique de la classe A est conforme à la norme NMB-003 du Canada.

European Union EMC Directive Conformance Statement

This product is in conformity with the protection requirements of EU Council Directive 2004/108/EC on the approximation of the laws of the Member States relating to electromagnetic compatibility. Force 10 Networks can not accept responsibility for any failure to satisfy the protection requirements resulting from a non-recommended modification of this product, including the fitting of non-Dell Force10 option cards.

This product has been tested and found to comply with the limits for Class A Information Technology Equipment according to CISPR 22/ European Standard EN 55022. The limits for Class A equipment were derived for commercial and industrial environments to provide reasonable protection against interference with licensed communication equipment.

 **WARNING:** This is a Class A product. In a domestic environment, this device may cause radio interference, in which case, the user may be required to take adequate measures.

European Community Contact

Dell Force10, EMEA - Central
 Dahlienweg 19
 66265 Heusweiler
 Germany

<http://www.force10networks.com/german/>

Tel: +49 172 6802630

Email: EMEA Central Sales

Japan: VCCI Compliance for Class A Equipment

この装置は、情報処理装置等電波障害自主規制協議会（VCCI）の基準に基づくクラスA情報技術装置です。この装置を家庭環境で使用すると電波妨害を引き起こすことがあります。この場合には使用者が適切な対策を講ずるよう要求されることがあります。

This is Class A product based on the standard of the Voluntary Control Council For Interference by Information Technology Equipment (VCCI). If this equipment is used in a domestic environment, radio disturbance may arise. When such trouble occurs, the user may be required to take corrective actions.

⚠ WARNING: AC Power cords are for use with Dell Force10 equipment only. Do not use Dell Force10 AC power cords with any unauthorized hardware.

本製品に同梱いたしております電源コードセットは、本製品専用です。本電源コードセットは、本製品以外の製品ならびに他の用途でご使用いただくことは出来ません。製品本体には同梱された電源コードセットを使用し、他製品の電源コードセットを使用しないで下さい。

Korea (MIC certification)**Korean Class A Warning Statement**

이 기기는 업무용으로 전자파 적합등록을 받은 기기 이오니, 판매자 또는 사용자는 이점을 주의하시기 바라며, 만약 잘못 구입하셨을 때에는 구입한 곳에서 비업무용으로 교환하시기 바랍니다.

Safety Standards and Compliance Agency Certifications

- CUS UL (60950-1, 1st Edition)
- CSA 60950-1-03, 1st Edition
- EN 60950-1, 1st Edition
- EN 60825-1, 1st Edition
- EN 60825-1 Safety of Laser Products—Part 1: Equipment Classification Requirements and User's Guide

- EN 60825-2 Safety of Laser Products—Part 2: Safety of Optical Fibre Communication Systems
- FDA Regulation 21CFR 1040.10 and 1040.11

Electromagnetic Compatibility (EMC)

Emissions

- Australia/New Zealand: AS/NZS CISPR 22: 2006, Class A
- Canada: ICES-003, Issue-4, Class A
- Europe: EN55022 2006 (CISPR 22: 2006), Class A
- Japan: VCCI V3/ 2007.04 Class A
- USA: FCC CFR47 Part 15, Subpart B, Class A

Immunity

- EN 300 386 V1.3.3: 2005 EMC for Network Equipment
- EN 55024 1998 + A1: 2001 + A2: 2003
 - EN 61000-3-2 Harmonic Current Emissions
 - EN 61000-3-3 Voltage Fluctuations and Flicker
 - EN 61000-4-2 ESD
 - EN 61000-4-3 Radiated Immunity
 - EN 61000-4-4 EFT
 - EN 61000-4-5 Surge
 - EN 61000-4-6 Low Frequency Conducted Immunity

Product Recycling and Disposal

This switch must be recycled or discarded according to applicable local and national regulations. Dell Force10 encourages owners of information technology (IT) equipment to responsibly recycle their equipment when it is no longer needed. Dell Force10 offers a variety of product return programs and services in several countries to assist equipment owners in recycling their IT products.

Waste Electrical and Electronic Equipment (WEEE) Directive for Recovery, Recycle and Reuse of IT and Telecommunications Products

Dell Force10 switches are labeled in accordance with European Directive 2002/96/EC concerning waste electrical and electronic equipment (WEEE). The Directive determines the framework for the return and recycling of used appliances as applicable throughout the European Union. This label, as shown in [Figure D-1](#), is applied to various products to indicate that the product is not to be thrown away, but rather reclaimed upon end of life per this Directive.

Figure D-1. The European WEEE symbol



In accordance with the European WEEE Directive, electrical and electronic equipment (EEE) is to be collected separately and to be reused, recycled, or recovered at end of life. Users of EEE with the WEEE marking per Annex IV of the WEEE Directive, as shown above, must not dispose of end of life EEE as unsorted municipal waste, but use the collection framework available to customers for the return, recycling and recovery of WEEE. Customer participation is important to minimize any potential effects of EEE on the environment and human health due to the potential presence of hazardous substances in EEE.

Dell Force10 products, which fall within the scope of the WEEE, are labeled with the crossed-out wheeled-bin symbol, as shown above, as required by WEEE.

For information on Dell Force10 product recycling offerings, see the WEEE Recycling instructions on iSupport at: <https://www.force10networks.com/CSPortal20/Support/WEEEandRecycling.pdf>.

For California:

Perchlorate Material — Special handling may apply.

See: <http://www.dtsc.ca.gov/hazardouswaste/perchlorate>

The foregoing notice is provided in accordance with California Code of Regulations Title 22, Division 4.5 Chapter 33. Best Management Practices for Perchlorate Materials.

Technical Support

This appendix contains these sections:

- The iSupport Website
- [Contacting the Technical Assistance Center on page 66](#)
- [Requesting a Hardware Replacement on page 66](#)
- [Locating E300 Serial Numbers on page 67](#)

The iSupport Website

iSupport provides a range of documents and tools to assist you with effectively using Dell Force10 equipment and mitigating the impact of network outages. Through iSupport you can obtain technical information regarding Dell Force10 products, access to software upgrades and patches, and open and manage your Technical Assistance Center (TAC) cases. Dell Force10 iSupport provides integrated, secure access to these services.

Accessing iSupport Services

The URL for iSupport is www.force10networks.com/support/. To access iSupport services you must have a userid and password. If you do not have one, you can request one at the website:

- 1 On the Dell Force10 iSupport page, click the **Account Request** link.
- 2 Fill out the User Account Request form, and click **Send**. You will receive your userid and password by E-Mail.
- 3 To access iSupport services, click the **Log in** link, and enter your userid and password.

Contacting the Technical Assistance Center

How to Contact Dell Force10 TAC	Log in to iSupport at www.force10networks.com/support/ , and select the Service Request tab.
Information to Submit When Opening a Support Case	<ul style="list-style-type: none"> • Your name, company name, phone number, and E-mail address • Preferred method of contact • Model number • Serial Number (see Locating E300 Serial Numbers on page 67) • Software version number • Symptom description • Screen shots illustrating the symptom, including any error messages. These can include: <ul style="list-style-type: none"> • Output from the show tech command or the show tech linecard {number} command • Output from the show trace command or the show trace linecard {number} command • Console captures showing the error messages • Console captures showing the troubleshooting steps taken • Saved messages to a syslog server, if one is used
Managing Your Case	Log in to iSupport, and select the Service Request tab to view all open cases and RMAs.
Download Software Updates	Log in to iSupport, and select the Software Center tab.
Technical Documentation	Log in to iSupport, and select the Documents tab. This page can be accessed without logging in via the Documentation link on the iSupport page.
Contact Information	<p>E-mail: support@force10networks.com</p> <p>Web: www.force10networks.com/support/</p> <p>Telephone:</p> <p>US and Canada: 866.965.5800</p> <p>International: 408.965.5800</p>

Requesting a Hardware Replacement

To request replacement hardware, follow these steps:

Step	Task
1	<p>Determine the part number and serial number of the component. To list the numbers for all components installed in the chassis, use the <code>show inventory</code> command.</p> <p> NOTE: The serial number for fan trays and AC power supplies will not appear in the hardware inventory listing. Check the failed component for the attached serial number label, as described next (see Locating E300 Serial Numbers on page 67).</p>

Step	Task
2	<p>Request a Return Materials Authorization (RMA) number from TAC by opening a support case. Open a support case by:</p> <ul style="list-style-type: none"> • Using the Create Service Request form on the iSupport page (see Contacting the Technical Assistance Center on page 66). • Contacting Dell Force10 directly by E-mail or by phone (see Contacting the Technical Assistance Center on page 66).
3	<p>Provide the following information when using E-mail or phone:</p> <ul style="list-style-type: none"> • Part number, description, and serial number of the component. • Your name, organization name, telephone number, fax number, and e-mail address. • Shipping address for the replacement component, including a contact name, phone number, and e-mail address. • A description of the failure, including log messages. This generally includes: <ul style="list-style-type: none"> • the <code>show tech</code> command output • the <code>show trace</code> and <code>show trace hardware</code> command output • for line card issues, the <code>show trace hardware linecard</code> command output • console captures showing any error messages • console captures showing the troubleshooting steps taken • saved messages to a syslog server, if one is used <p>The support representative will validate your request and issue an RMA number for the return of the component.</p>
4	<p>Pack the component for shipment, preferably using the original shipping container materials. Label the package with the component RMA number. For details on removing and replacing components, see Removing and Replacing Components on page 45.</p>

Locating E300 Serial Numbers

Currently, in nearly all cases, the serial number has a two-letter preamble followed by nine digits, and is displayed both in text and below an equivalent bar code, usually on the component's faceplate.

Chassis: The serial number of the chassis is located on a sticker on the back of the chassis at the bottom center to the right of a part number sticker. You can also use the `show chassis` command in FTOS to display the serial number.

Figure E-1. Serial Number on Back of Chassis

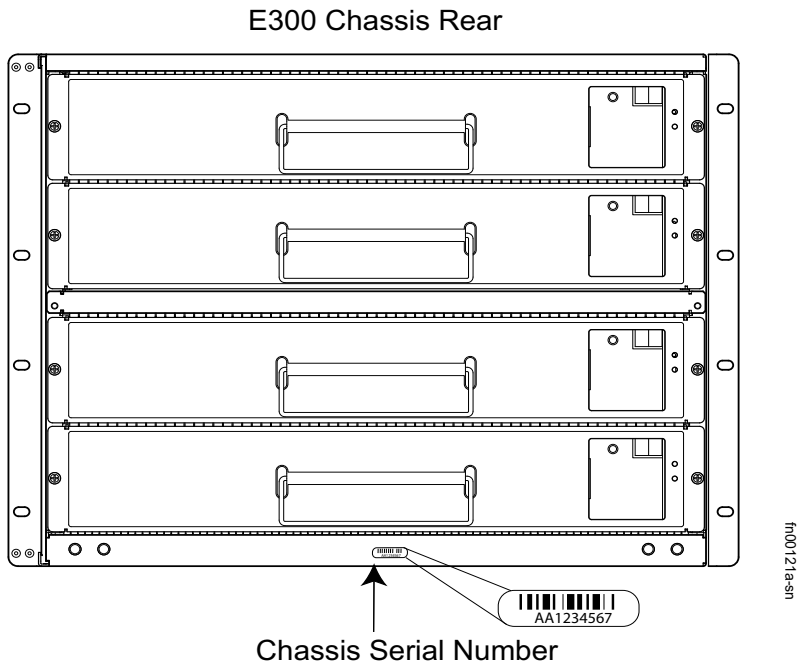

Line Card: The serial number of any E300 line card is located on the far right of its faceplate (Figure E-2).

Figure E-2. Serial Number on 48-port 1-Gigabit Line Card

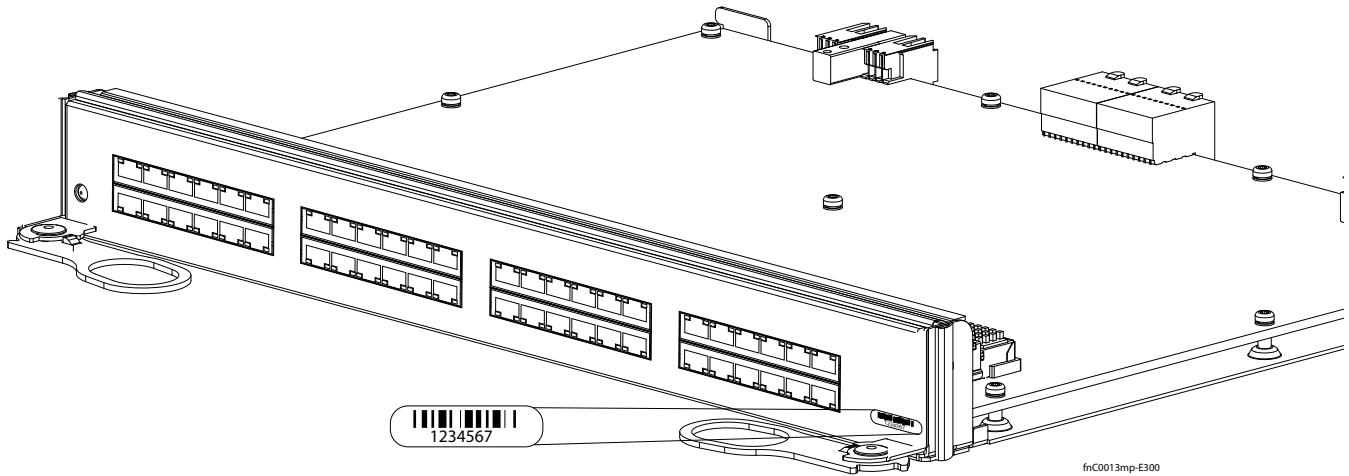

Route Processor Module (RPM): The serial number of the RPM is located on the left side of its faceplate (Figure E-3).

Figure E-3. Serial Number on Route Processor Module

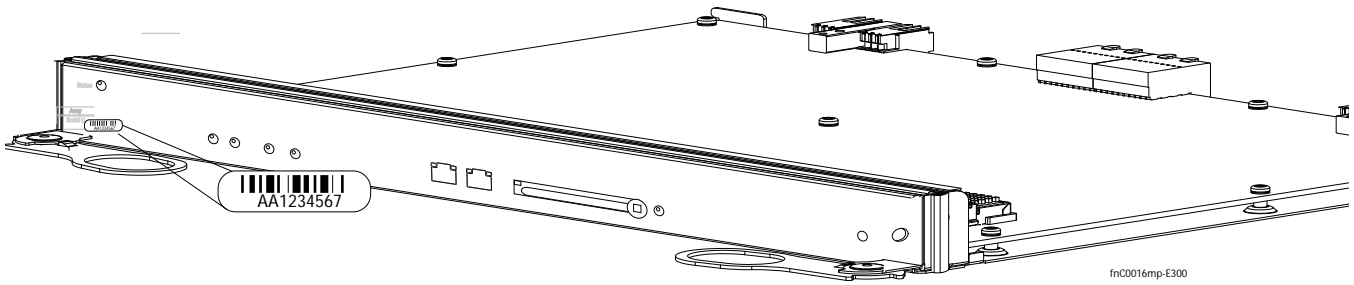

Power Supply: The serial number of the power supply module is located on the right side of its faceplate, as oriented in [Figure E-4](#).

Figure E-4. Serial Number on Power Supply Module



SFM: The serial number of the Switch Fabric Module (SFM) is located on the bottom of its faceplate ([Figure E-5](#)).

Figure E-5. Serial Number on SFM



Fan Tray: The serial number of the fan tray is located at the base of its faceplate ([Figure E-6](#)).

Figure E-6. Serial Number on Fan Tray

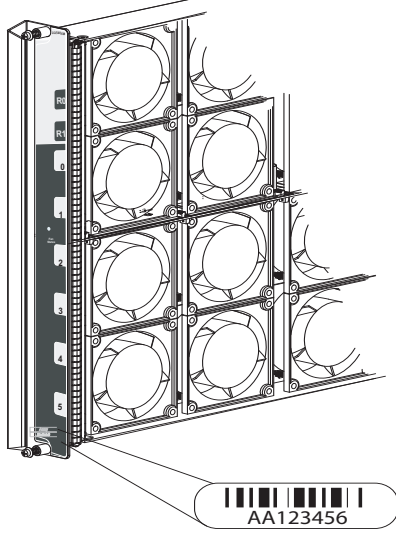

Index

A

- AC power supplies
 - installing 22
- air filter
 - replacing 48
- air flow 14, 16
- alarms
 - fan trays 45
 - line cards 47
 - PEMs 46
 - relay contacts on RPM 33
 - resetting the alarm relay contacts 33
 - RPMs 47
 - SFMs 47

B

- blanks 31

C

- cable management system 34
- chassis serial number 67
- Compact flash
 - formatting 56
 - inserting 55
 - removing 55
- Compact Flash Card 55
- connecting
 - auxiliary port 39
 - console port 39
 - management port 42

D

- Danger 7
- DC PEM, installing 22
- DC Power Requirements 15
- disposal, switch 63

E

- ESD 31, 47
- European WEEE Directive 64
- external flash
 - copying files 56

F

- fan tray serial number 69
- fan tray, replacing 46

- flash memory card, external 55

I

- installing
 - AC power supplies 22
 - DC power supplies 22
 - fan tray 29
 - line cards 31
 - RPM 32
 - SFMs 35

L

- LEDs
 - AC power supplies 27
 - fans 27, 44
 - In Use LED 55
 - Major Alarm 33
 - Minor Alarm 33
 - PEM Status 27
 - PEM Voltage LED 27
 - RPM Status 34
- line card serial number 68
- line card, removing 48

M

- modem
 - connecting to the system 41, 42

N

- numbering
 - RPM slots 31

P

- PEMs
 - installing 22
 - replacing 46
- pin assignments
 - auxiliary port 41
 - console port 40
 - DB-9 adapter 41
- power
 - turning off 44
 - turning on 43
- power supply module serial number 69
- power supply module, removing 47

R

- rack
 - placement 14
- recycling, switch 63
- removing
 - air filters 48
 - fan trays 46
 - line cards 48
 - PEMs 47
 - RPMs 48
 - SFM 48
- RPM 55
- RPM serial number 68
- RPM, installing 32
- RPM, removing 48

S

- safety considerations
 - cabinet placement 14
 - rack mounting 14
- Serial Numbers, Locating E300
 - Locating E300 Serial Numbers 67
- SFM, installing 35
- SFM, removing 48
- specifications
 - chassis 59
 - environmental 13
- Switch Fabric Module (SFM) serial number 69
- switch recycling 63
- system boot
 - BOOT_USER 51
 - break control sequence 51
 - commands
 - ? 51
 - boot change 52
 - help 51
 - interface management ethernet ip address 54
 - interface management port config 100m 54
 - interface management port config 10m 54
 - interface management port config auto-negotiate 54
 - interface management port config full-duplex 54
 - interface management port config half-duplex 54
 - interface management port config no auto-

- negotiate 54
- interface management port config show 54
- reload 54
- show bootflash 53
- show bootvar 53
- show interface management ethernet 54

W

- Warning 8
- WEEE 64



Printed in the U.S.A.

www.dell.com | support.dell.com